



PRODUCT SPECIFICATION

DOC NO: SDHTLPS/C-RE-PS-006

REV : 1.0

PAGE : 1 of 7

PRODUCT SPECIFICATION

Product Name: Coin-type Supercapacitor

Product Model: SC5R5104Z-C

Prepared by: Yong Wang

Checked by: Yong Wang

Approved by: Xiaoxu He

Shan Dong Heter Lampson Electronic Co., Ltd.



PRODUCT SPECIFICATION

DOC NO: SDHTLPS/C-RE-PS-006

REV : 1.0

PAGE : 2 of 7

List

1.Scope.....	3
2.Standard Testing Condition.....	3
3. General Characteristics.....	3
4. Environmental Characteristics.....	3
5. Product Dimensions.....	4
6.Part Number system	4
7.The Measurement Methods	5
8. Handling Precautions and Guidelines.....	6



PRODUCT SPECIFICATION

DOC NO: SDHTLPS/C-RE-PS-006

REV : 1.0

PAGE : 3 of 7

1. Scope

This product specification describes the characteristics of coin-type supercapacitor produced by Shan Dong Heter Lampson Electronic Co., Ltd.

2. Standard Testing Condition

All test and measurements shall be made under standard atmospheric conditions(Temperature: 15~35°C, Relative humidity: 25%~75%)for testing. Before the measurements are made, the supercapacitor shall be store at the measuring temperature for a time sufficient to allow the entire supercapacitor to reach this temperature. All tests of the specification book were carried out under the following environmental conditions:

Temperature: 25±1°C Humidity: (60±15) % RH Air pressure: 86~106KPa

3. General Characteristics

Item		Specification	
1	Model	SC5R5104Z-C	
2	Rated discharge capacitance	0.10 F	
3	Capacitance tolerance	-20%~+80%	
4	Rated voltage	5.5V	
5	Surge voltage	6.0 V	
6	Nominal impedance	AC Imp	75 Ω
		DC Imp	110 Ω
7	Working temperature range	-25~70°C	
8	Storage temperature range	-40~85°C	
9	Cycle life	Standard charge-discharge mode > 100000 cycles, ΔC/C ≤30%, ESR≤ 4 times of specified ESR	

4. Environmental Characteristics

Item	Specification/Condition
1	Temperature characteristics ΔC/C ≤30%, ESR≤ specified ESR(25°C) at +70°C ΔC/C ≤50%, ESR≤ 4 times of specified ESR (25°C) at -25°C
2	High temperature load ΔC/C ≤30% , ESR≤ 4 times of specified ESR (25°C) at +70±2°C/1000hrs/rated voltage
3	High temperature storage ΔC/C ≤30% , ESR≤2 times of specified ESR (25°C) at +70±2°C/1000hrs/standby after fully charge
4	Humidity Resistance +40°C±2, 90--95%RH, 240h, ΔC/C ≤30%,IL≤2 times of specified leakage current, ESR≤4 times of specified ESR (25°C)



PRODUCT SPECIFICATION

DOC NO: SDHTLPS/C-RE-PS-006

REV : 1.0

PAGE : 4 of 7

5. Product Dimensions

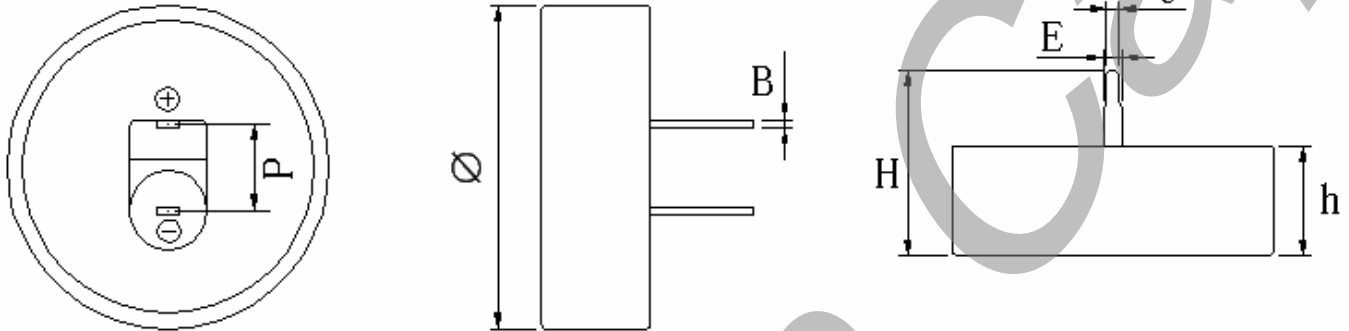

Item	Criteria	Item	Criteria
Φ	13.5±0.5 mm	H	13.5±0.5 mm
h	7.0±0.5 mm	p	5.0±0.5 mm
E	1.2±0.2mm	B	0.40±0.05 mm
C	0.8±0.1 mm		

6. Part Number system

S □ □ □ □ □ □ □ □ □ □

- ▶ Lead pin designation, V; H; C
- ▶ Tolerance designation, Z means tolerance of -20% ~ +80%
- ▶ Capacitance designation, noted by three arabic numerals, e.g. 474 means $47 \times 10^4 \mu\text{F}$
- ▶ voltage designation, 2R7 means voltage of 2.7V, 5R5 means voltage of 5.5V
- ▶ Shape designation, "R" means Rotundity, "C" means Coin, "P" means Prismatic
- ▶ "S" means Supercapacitor

7 The Measurement Methods

7.1 Capacitance (Constant current discharge method)

- 1) Turn the switch S to the DC power supply, charge the supercapacitor with constant current

(general 2mA) to rated voltage(U_R);

- 2) Constant voltage charge at rated voltage(U_R) for 30min;

- 3) Discharge the supercapacitor with constant current(general 2mA) to 0.1V.

Constant current/
constant voltage power
supply

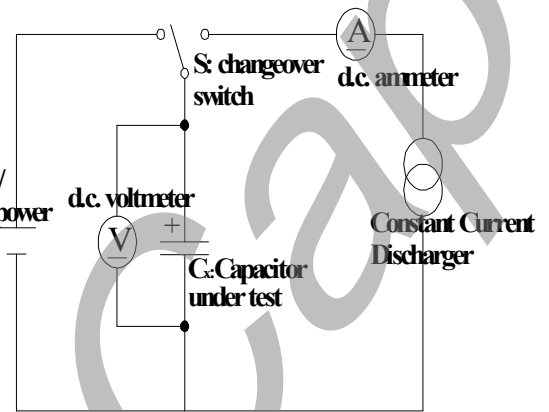

Figure1. Circuit for constant current discharge method

Measure the time t_1 to t_2 where the voltage between capacitor terminals at the time of discharge reduces from U_1 to U_2 as shown figure2 and calculate the capacitance value by the following formula:

$$C = \frac{I \times (t_2 - t_1)}{U_1 - U_2}$$

where: C: is the capacitance (F)

I: is the discharge current (A)

t_1 : is the time from discharge start to reach U_1 (s)

t_2 : is the time from discharge start to reach U_2 (s)

U_1 : is the measurement starting voltage (V)

U_2 : is the measurement end voltage (V)

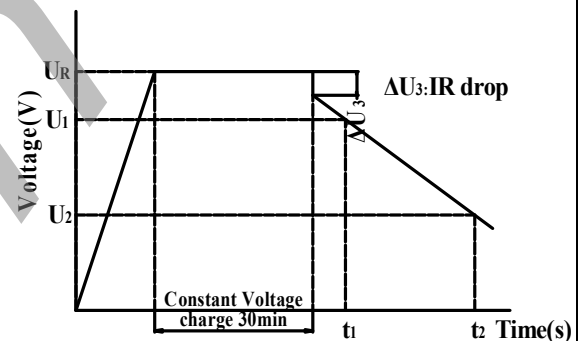

Figure2. Curve for charge-discharge

7.2 Internal resistance

7.2.1 DC resistance method

$$R_{DC} = \frac{U_3}{I}$$

where: R_{DC} : is the DC internal resistance(Ω)

U_3 : is the drop voltage for 10ms(V)

I: is the discharge current(A)

7.2.2 AC resistance method

Measure AC internal resistance by the LCR meter (Frequency: 1KHz)

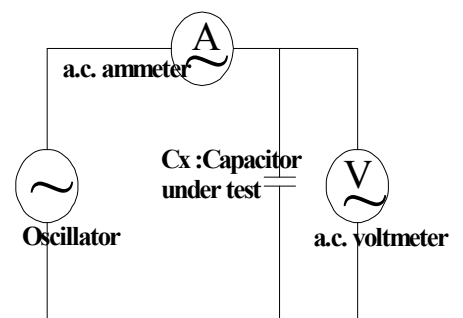

Figure3. Circuit for AC internal resistance method



PRODUCT SPECIFICATION

DOC NO: SDHTLPS/C-RE-PS-006

REV : 1.0

PAGE : 6 of 7

The internal resistance R_{AC} of a supercapacitor shall be calculated by the following formula:

$$R_{AC} = \frac{U}{I}$$

where: R_{AC} : is the AC internal resistance(Ω)
 U : is the effective value of AC voltage (V r.m.s)
 I : is the effective value of AC current (A r.m.s)

7.3 Leakage current

1) Before this measurement is made, the capacitors shall be fully discharge.

Discharge procedure shall take more than 1h;

2) Apply rated voltage to the supercapacitor;

3) Measure U_V after 30min、12h、24h、72h

Calculator current using the following formula :

$$LC = \frac{U_V}{R} \times 10^3 mA$$

Where : LC : is the Leakage current(mA)
 U_V : is the voltage between capacitor terminals(V)
 R : is the protective resistor of 1000Ω or less(Ω)

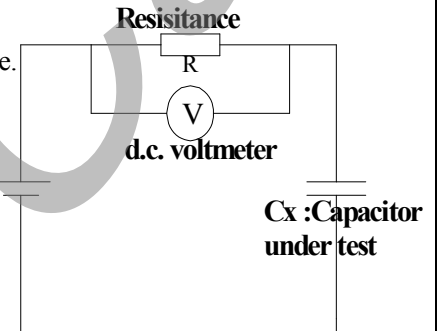

Figure4.Circuit for leakage current method

8.Handling Precautions and Guidelines

For safety application, please contact Lampson directly for any technical specifications, handling precautions and guidelines critical to application.

8.1 Precautions

(1) Prohibition of disassembly

The disassembling may generate internal short circuit in the cell, which may cause gassing, leakage, explosion, or other problems.

Electrolyte is harmful: In case the electrolyte come into contact with the skin, or eyes, physicians shall flush the electrolyte immediately with fresh water and medical advice is to be sought.

(2) Prohibition of dumping of cells into fire

These may cause explosion of the cells, which is very dangerous and is prohibited.

(3) Prohibition of cells immersion into liquid

The cells shall never be soaked with liquids such as water, seawater, drinks such as juices, coffee or others.

(4) Prohibition of use of damaged cells

The cells might be damaged during shipping by shock. If any abnormal features of the cells are found such as damages in the cell package, smelling of an electrolyte, an electrolyte leakage and others, the cells shall never be used any more.



PRODUCT SPECIFICATION

DOC NO: SDHTLPS/C-RE-PS-006

REV : 1.0

PAGE : 7 of 7

The Cells with a smell of the electrolyte or a leakage shall be placed away from fire to avoid firing or explosion.

8.2 Handling Guidelines

- (1) It is not suitable that cell is used under such conditions: AC circuit and wave filtering.
- (2) Work voltage of cell should not exceed Max. work voltage of cell during using. Otherwise, will shorten shelf life, even cause swelling, leakage or crack..
- (3) Please check the polarity before using. If working under reverse polarity, cell will not only shorten shelf life, but also heavy damage, such as swelling, electrolyte leakage etc.
- (4) Environment
Work temperature will have an influence on shelf life of cell. As usual, higher work temperature will shorten shelf life. So, it is better that cell works under as possible as low environmental temperature.
Work temperature of cell should consider internal work temperature in the unit and temperature rise when cell works.
- (5) IR drop
When main power sources shut down, cell will change into work mode from failure mode, at the same time, OCV will decrease due to IR drop. So please choose proper product type according to impedance specified in product datasheet and applied current.
- (6) Cells in series connection
When cells in series connection for higher work voltage, it should be assured that work voltage of any single cell must not exceed Max. work voltage of single cell, otherwise, will shorten shelf life, even cause swelling, leakage or crack.
- (7) Soldering
Heat shock will decrease electric performance of cell, even cause swelling, leakage or crack.
Soldering temperature should not exceed 230°C, soldering time should not exceed 5s.
- (8) Please don't use reflow soldering of infrared heating and air heating.