

## Swing Check Valve

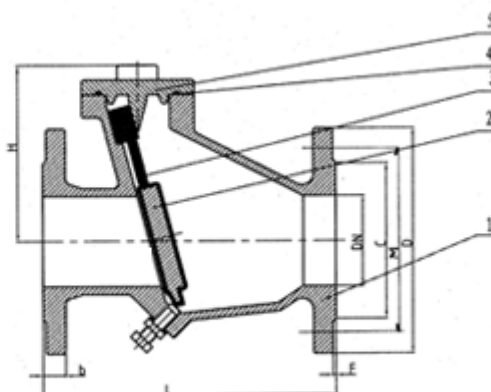

### DESCRIPTION

- 1.Face to Face:DIN3202 F6, BS5153
- 2.Flange drilled: DIN2501, BS4504
- 3.Normal pressure: 1.0MPa, 1.6MPa, 2.5MPa
- 4.Suitable medium: water
- 5.Working temperature: NBR≤80°C, EPDM≤120°C

### MATERIAL LIST

No.	PART	MATERIAL
1	BODY	GGG40/GGG50
2	DISC CORE	GGG40/GGG50
3	DISC	EPDM/NBR
4	RUBBER SEAL	EPDM/NBR
5	BONNET	GGG40/GGG50

### DIMENSION(mm).PN16

DN	L		b		D	C	M	H	F	n-d
	DIN3202	BS5153	DIN3202	BS5153						
50	200	203	19	19	165	102	125	118	3	4-19
65	240	216	19	19	185	122	145	135	3	4-19
80	260	241	19	19	200	138	160	160	3	8-19
100	300	292	19	19	220	158	180	182	3	8-19
125	350	330	19	19	250	188	210	205	3	8-19
150	400	356	22	19	285	212	240	235	3	8-23
200	500	495	22	20	340	268	295	275	3	12-23
250	600	622	26	22	405	320	355	320	3	12-28
300	700	698	26	25	460	378	410	365	4	12-28
350	800	787	27	27	520	438	470	400	4	16-28
400	900	864	28	28	580	490	525	430	4	16-31