

DIN CAST IRON NON-RISING STEM GATE VALVE, METAL SEATED, F5 PN16

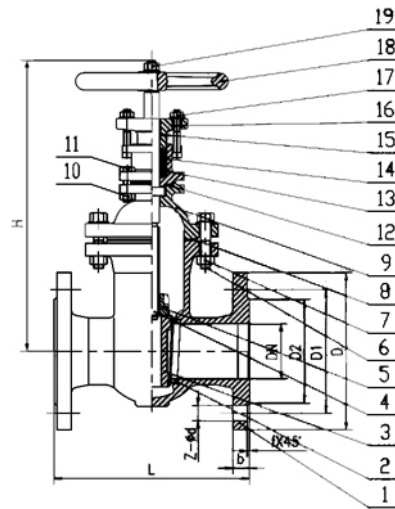

DESCRIPTION:

Available Medium: Water, Steam

Working Temperature: $\leq 200^{\circ}\text{C}$

Face to Face Dimensions: DIN3202 F5

Flange Dimensions: DIN2501

DIMENSIONS (MM)										
DN	L	D	D1	D2	b	Z- ϕ d	f	D0	H	KG
40	240	150	110	88	18	4-18	3	180	264	15
50	250	165	125	102	20	4-18	3	180	280	20.3
65	270	185	145	122	20	4-18	3	240	326	28
80	280	200	160	138	22	8-18	3	240	340	31.7
100	300	220	180	158	22	8-18	3	280	376	42.4
125	325	250	210	188	24	8-18	3	320	486	59.8
150	350	285	240	212	24	8-23	3	320	535	76.82
200	400	340	295	268	26	12-23	3	360	634	114.5
250	450	405	355	320	28	12-27	3	400	750	170
300	500	460	410	378	28	12-27	4	500	826	240.8
350	550	520	470	438	30	16-27	4	500	915	293.4
400	600	580	525	490	32	16-30	4	560	978	421.9

MATERIALS		
ITEM	PARTS NAME	MATERIAL
1	BODY	CAST IRON
2	SEAT	BRASS
3	WEDGE DISC	CAST IRON+BRASS
4	STEM	STAINLESS STEEL
5	STEM NUT	BRASS
6	BOLT	CARBON STEEL
7	NUT GASKET	CARBON STEEL
8	GASKET	GRAPHITE
9	BONNET	CAST IRON
10	NUT GASKET	CARBON STEEL
11	BOLT	CARBON STEEL
12	GASKET	GRAPHITE
13	SUFFING BOX	CAST IRON
14	PACKING	GRAPHITE
15	GLAND	CAST IRON
16	BOLT	CARBON STEEL
17	NUT GASKET	CARBON STEEL
18	WHEEL	CAST IRON
19	NUT GASKET	CARBON STEEL