

# GM-739, Ultra High Performance, Easy to Use GPS Smart Antenna Module with RF Connector

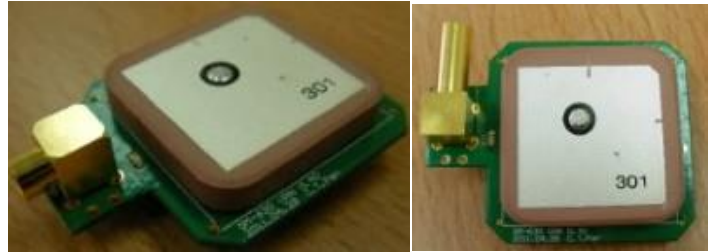

## Overview

GM-739 is equipped with the **u-blox 7** low-power, high-sensitivity engine. The dual-antenna design allows it to be flexibly used in various GPS environments.

An electronic antenna switch is built-in for automatic switch between built-in and external antennas. Antenna short-circuit protection prevents it from damage due to accidental human mistakes.

Our experienced design provides not only fast acquisition and excellent tracking performance but also quality and delivery assurance.

## Applications

- Camera detector
- Driving Recorder
- Automatic vehicle location

## Features

- Easy to use with built-in patch antenna, backup battery, RF connector, and 12-pin digital connector.
- External active antenna short circuit protection
- Automatic switch between the built-in passive antenna and external active antenna.
- Power control pin option
- Supports TTL, RS232, or USB interface
- Up to 10Hz update rate (default 1Hz)
- Excellent EMI protection and minimum RF efforts
- High performance: -161dBm tracking sensitivity

- OMA SUPL compliant A-GPS support
- SBAS (WAAS, EGNOS, MSAS) support
- LED for position fix indication
- Industrial operating temperature range: -40 ~ 85°C

## Technical Specifications

### Receiver Performance Data

Receiver Type	56-channel u-blox 7 engine GPS & QZSS:L1 C/A,1575.42MHz, SBAS: WAAS, EGNOS, MSAS
Horizontal Position Accuracy	< 2.5m (Autonomous) < 2.0m (WAAS) (CEP, 50%, 24-hour static, -130dBm, SEP < 3.5m)
Velocity Accuracy	<0.1 m/s (speed) <0.5° (heading) (50% @ 30m/s)
Time To First Fix	Autonomous (All at -130dBm)
Hot start	1sec
Warm start	28sec
Cold start	30sec (50% -130dBm)
Sensitivity (Autonomous)	-147dBm (acquisition) -161dBm (tracking)
Max. Update Rate	10Hz (default 1Hz)
Max. Altitude	50,000 m
Max. Velocity	500 m/s
Protocol Support	NMEA 0183 v2.3(compatible to 3.0)

**Navisys Technology Corp.**

Tel : +886-3-5632598

Sales contact: [sales@navisys.com.tw](mailto:sales@navisys.com.tw)

Address: 2F, No.56, Park Ave. II, Science-Based Industrial Park, Hsinchu 300, Taiwan (R.O.C.)

<http://www.navisys.com.tw/>

Fax: +886-3-5632597

Technical support: [service@navisys.com.tw](mailto:service@navisys.com.tw)

	Baud rate: 1200~115200 bps UART: 9600 (default) bps N,8,1; USB: baud selectable GGA, GLL, GSA, GSV, RMC, VTG, TXT
SBAS Support	WAAS, EGNOS, MSAS
Dynamics	< 4g

**Electrical Data**

Power Supply (V)	3.5 ~ 5.5 (Recommended) 3.3 ~ 3.5 (Vpp < 50mV)
Power Consumption	39mA/average tracking 49mA/average acquisition
TTL I/O (V)	V <sub>IH</sub> : 0.7*VCC~VCC+0.5, V <sub>IL</sub> : 0 ~ 0.2*VCC V <sub>OH</sub> : >= VCC-0.4, V <sub>OL</sub> <= 0.4
Protocols	NMEA, u-blox Binary

**RF Interface**

Built-in patch antenna	25x25x4 mm <sup>3</sup>
External RF connector	MCX, SMA, I-PEX

**Environmental Data**

Operating temperature	-40 ~ 85°C except supercap: -10~60°C
Storage temperature	-40 ~ 85°C except supercap: -10~60°C

**Mechanical Data – 30 x 39 x 12.2 (mm)**

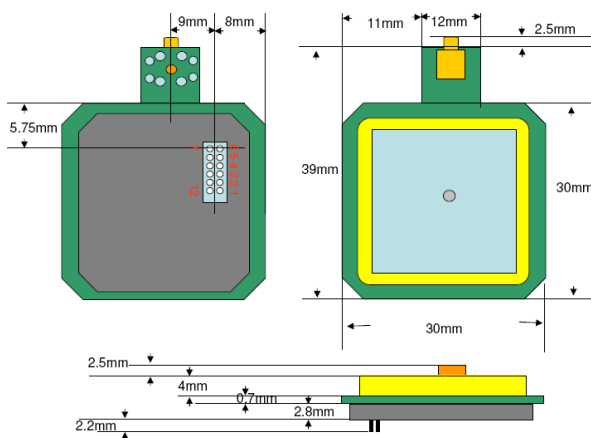

**12-pin Interface (default), pitch 1.27mm**

Pin	Name	Function	I/O
1,12	NC <sup>0</sup> /or RS232-TX <sup>1</sup> / or PWR_SAV <sup>2</sup>	NC (default setting) / or option 1: RS232 level serial data output from GPS / or option 2: Normal: 0, Power off: 1	Input <sup>2</sup> / or Output <sup>1</sup>
2,11	VCC	Power supply (3.3~5.5V)	Input
3,10	TTL-TX/D+	TTL level serial data output (from GPS) / USB D Plus	Output / IO
4,9	TTL-RX/D-	TTL level serial data input (into GPS) / USB D Minus	Input / IO
5,8	GND	Ground	Input
6	NC <sup>0,2</sup> /or RS232-RX <sup>1</sup> /	NC (default setting) / or option 1: RS232 level serial data input into GPS	Input
7	NC	No Connection	-

Note. 0/1/2 : default/option 1/option 2 setting **On-board LED**

The GPS fix status is indicated by an on-board LED.

LED always ON: not fixed; LED blinks: position fixed

**Ordering Information**

**GM-739X**

A <sup>1</sup>	Patch antenna, no RF connector GGA, GLL, GSA, GSV, RMC, VTG, TXT TTL
D	Patch antenna, SMA RF connector GGA, GLL, GSA, GSV, RMC, VTG, TXT RS232
T	Patch antenna, SMA RF connector GGA, GLL, GSA, GSV, RMC, VTG, TXT TTL
U	USB, patch antenna, MCX RF connector GGA, GLL, GSA, GSV, RMC, VTG, TXT Connectors: MCX, 12-pin header

Note 1. GM-739A is the standard model

\*This document is subject to change without notice.