

FLANGE END AND SCREW END AIR VALVE

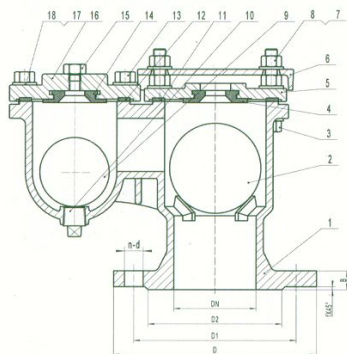

Technical Requirement:

1. PQ-16 conforms to JKR20200-0043-99.
2. Flange drilled conforms to BS EN1092.
3. DN25 is joint by screw thread.

MATERIAL LIST			
NO.	Name of part	Material	British standard
1	body	ductile iron	BS2789 Gr500-7
2	float ball	plastic ABS	ISO 2580
3	bolt	steel	BS970 43A
4	ball seal large orifice	EPDM	BS2494 Type W
5	large orifice cover	ductile iron	BS2789 Gr500-7
6	dust cap	ductile iron	BS2789 Gr500-7
7	nut	steel	BS970 43A
8	washer	steel	BS970 43A
9	float ball	plastic ABS	ISO 2580
10	screw plug	brass	BS1400 PCB1
11	ball seal large orifice	EPDM	BS2494 Type W
12	gasket	EPDM	BS2494 Type W
13	bolt	steel	BS970 43A
14	sealed orifice	EPDM	BS2494 Type W
15	screw plug	brass	BS1400 PCB1
16	small orifice cover	ductile iron	BS2789 Gr500-7
17	nut	steel	BS970 43A
18	washer	steel	BS970 43A

SCOPE OF APPLICATION	
Nominal Pressure	1.6MPa
Shell Pressure	2.4MPa
Seat Pressure	1.76MPa
Suitable Medium	water
Temperature	<100℃

DIMENSIONS(MM)						
SIZE	D	D1	D2	B	f	n-d
40	150	110	84	19	3	4-19
50	165	125	99	19	3	4-19
65	185	145	118	19	3	4-19
80	200	160	132	19	3	4-19
100	220	180	156	19	3	8-19
125	250	210	184	19	3	8-19
150	285	240	211	19	3	8-23
200	340	295	266	20	3	12-23
250	405	355	319	22	3	12-28