



# 愛立德（香港）有限公司 INEED (HK) LIMITED

Company No.: 1448665 - Registered Office: Room 1103, Hang Seng Mongkok Building, 677 Nathan Road, Mongkok, Kowloon, Hong Kong  
Shenzhen Representative Office: 1-1-1E, Tianjiao Garden, Jinhua Rd., District 76, Bao'An, Shenzhen, Guangdong 518101, China  
Tel/ Fax: (+86) 755 2970 3859 URL: <http://www.ineed.hk>

## 產品規格說明書

### Product Specification

客戶名稱 Buyer Name		客戶代碼 Buyer Code	
產品名稱 Product Name	Coin Type Micro Vibration Motor	產品編碼 Product Part No.	C0827BE03L27
規格書號 Specification No.	IND20100620S019A	發佈日期 Date of Release	2012-05-14

聲明：本產品符合歐盟 2005/618/EC 環保指令相關要求。

We declare that the product is compliant with EU 2005/618/EC directives.

貴司確認本產品樣品後，在決定採購本產品之前，請您仔細閱讀本產品規格說明書，並在客戶承認欄內簽名及蓋章並回傳此頁給我司相關人員備案。After you approve the product samples, please read this specification carefully and return this page to us with your signature and company chop in below *Customer Approval* table before you decide to purchase this product.

客戶承認欄 Customer Approval				
	工程 Engineering	品質 Quality	生產 Production	採購 Procurement
簽名及蓋章 Signature & Company Chop				
日期 Date				

愛立德工廠承認欄 INEED Factory Approval			
	批准 Approved by	審核 Checked by	編制 Prepared by
簽名及蓋章 Signature & Company Chop	幹方飛 FF GAN	易紅婷 HT YI	周嫻靜 XJ ZHOU
日期 Date	2012-05-14	2012-05-14	2012-05-14

## 產品編碼解說 (扁平型振動電機)

### DEFINITION OF PART NUMBERS - COIN TYPE VIBRATION MOTORS

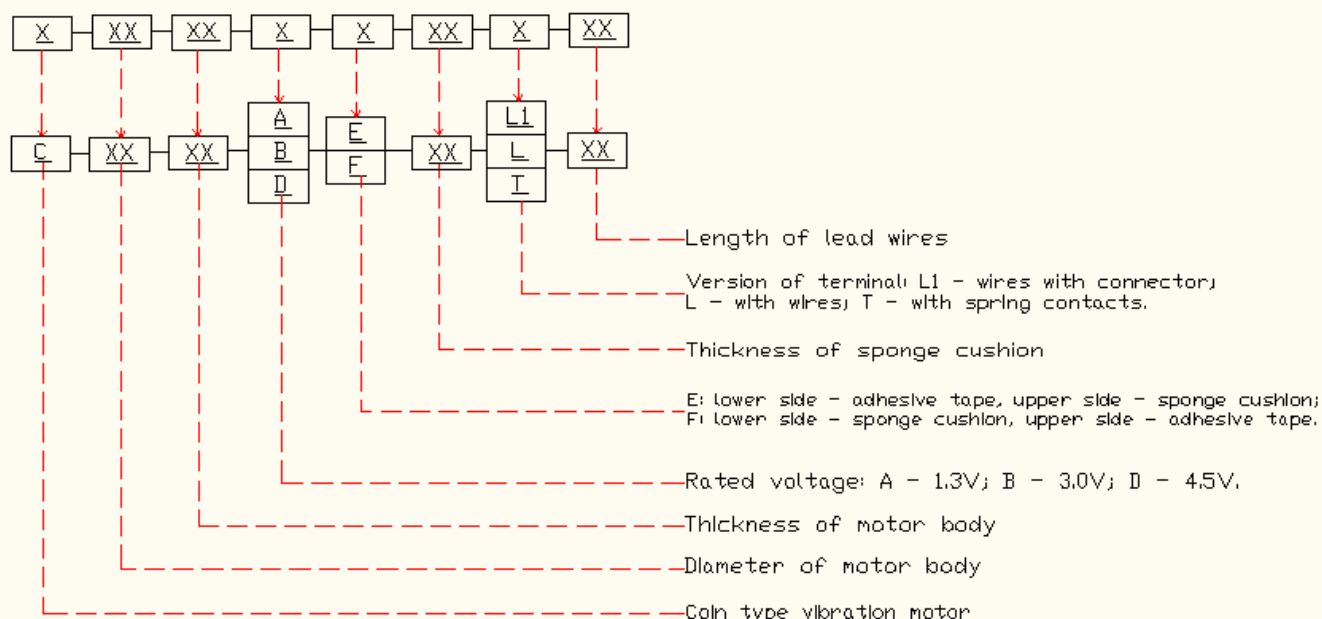

## 目錄 Contents

章節 Paragraph	標題 Headlines	頁碼 Page
1	適用範圍 General Scope	2
2	使用條件 Operating Conditions	2
3	初期電氣性能 Initial Electrical Characteristics	2
4	機械性能 Mechanical Characteristics	3
5	可靠性 Reliability	4
6	可靠性測試後期要求 Requirements after Reliability Tests	5
7	使用時注意事項 Precautions in Use	5
8	外形圖 Outline Drawing	6
9	包裝說明 Packaging	7
10	變更記錄表 Record of Changes	8

# 規格說明SPECIFICATIONS

## 1. 適用範圍 General Scope

本產品規格說明書適用於我司生產的扁平型微型振動電機，產品編碼為C0827BE03L27。

This product specification applies to our coin type micro vibration motor, part number C0827BE03L27.

## 2. 使用條件 Operating Conditions

序號 No.	專案 Items	規格 Specifications
2-1	額定電壓 Rated Voltage	3.0 V DC
2-2	使用電壓範圍 Operating Voltage Ranges	2.4-3.6V DC
2-3	使用溫度範圍 Operating Temperature Ranges	工作溫度 Working Temperature: -20°C~+60°C; 貯存溫度 Storage Temperature: -30°C~+70°C。

## 3. 初期電氣性能 Initial Electrical Characteristics

序號 No.	專案 Items	規格 Specifications	測定條件 Measuring Conditions
3-1	額定轉速 Rated Speed	13,000±3,000 RPM	額定電壓下。 At rated voltage.
3-2	額定電流 Rated Current	100mA Max	
3-3	起動電流 Starting Current	180mA Max	
3-4	起動電壓 Starting Voltage	2.3V DC Max	在此電壓下馬達必須能夠起動。 Motors shall be able to start at this starting voltage.
3-5	絕緣電阻 Insulation Resistance	10MΩ Min	100V 直流電下，導線和機殼間。 At 100V DC, between the lead wires and the housing.
3-6	端子阻抗 Terminal Resistance	27Ω±15% / 54Ω±15%	在 25°C 下。 At 25°C.

說明：上述數據在常溫常濕下測試。若對測試結果有任何疑議，均以溫度 25±3°C、相對濕度 65±20%環境下的測試數據為準。

Notes: Above data are measured at room temperature and humidity. For any doubts about the judgment, measurements shall be made at such environment: temperature - 25±3°C, related humidity - 65±20%.

#### 4. 機械性能 Mechanical Characteristics

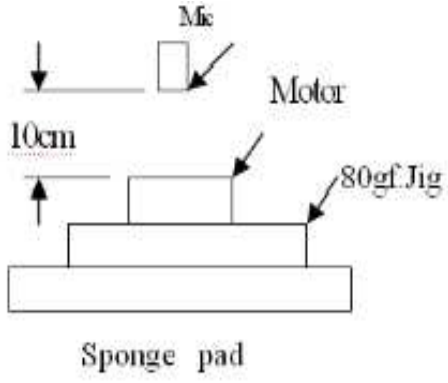
序號 No.	專案 Items	規格 Specifications	測定條件 Measuring Conditions
4-1	外形尺寸 Configuration	參照章節 8、外形圖。 As specified in Paragraph 8. Outline Drawing.	
4-2	重量 Mass	1.0±0.3 g	
4-3	外觀 Appearance	無機械損傷、無嚴重銹蝕。 There shall be no evidence of mechanical damage and severe corrosion.	
4-4	Mechanical Noise 機械雜訊	小於 50 分貝(A 計權) 50dB(A)Max.	<p>將電機固定於 80g 的夾具放置於海綿墊上，Mic 與電機間距 10cm。在額定電壓下測試。 背景噪音：不大於 28 分貝(A 計權)。</p> <p>Fix the motor with a jig of 80g and place it onto a sponge pad. Distance between the Mic and the motor: 10cm. Measure it at rated voltage. Back ground noise: 28dB(A) Max.</p>  <p>The diagram illustrates the measurement setup. At the bottom is a 'Sponge pad'. On top of it is an '80gf Jig'. A 'Motor' is mounted on the jig. A 'Mic' (microphone) is positioned above the motor, with a vertical distance of '10cm' between them. Arrows indicate the vertical alignment and the distance measurement.</p>

## 5. 可靠性 Reliability

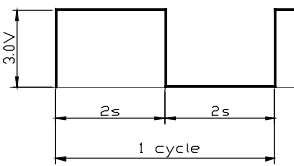
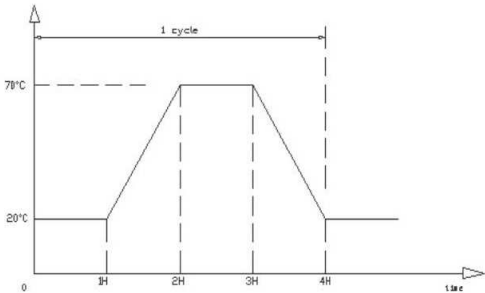
序號 No.	專案 Items	規格 Specifications	判定標準 Judgments
5-1	壽命 Lifetime	試驗迴圈 Test cycle: 50,000 cycles 	試驗後，馬達應符合章節 6 的要求。 After the test, motors shall be approved as specified in Paragraph 6.
5-2	低溫放置 Low Temperature Exposure	溫度 Temperature: $-30^{\circ}\text{C}$ 時間 Time: 72 hours	在常溫常濕下放置 4 小時後，馬達應符合章節 6 的要求。 After being exposed in room temperature and humidity for 4 hours, motors shall be approved as specified in Paragraph 6.
5-3	高溫放置 High Temperature Exposure	溫度 Temperature: $+70^{\circ}\text{C}$ 時間 Time: 72 hours	
5-4	濕度放置 High Humidity Exposure	溫度 Temperature : $+40^{\circ}\text{C}$ 濕度 Humidity: 95%RH 時間 Time: 72 hours 無水氣凝結 No condensation of moisture.	
5-5	自然跌落 Free Fall	試驗狀態：將馬達固定在約 100 克（包括馬達本身）的物體上，從 1.5 米高處自由落向水泥地面。 Test Status: Fix the motor on a block of approximately 100g (including motor itself) and drop them freely onto the concrete floor from a height of 1.5 meters. 方向 Direction: $\pm x, \pm y, \pm z$ 次數 No. of Times: 3 times each direction	測試結果應符合章節 6 的要求。 After the test, motors shall be approved as specified in Paragraph 6.
5-6	熱衝擊 Heat Shock Test	試驗迴圈 Test Cycle: 10 cycles 	測試結果應符合章節 6 的要求。 After the test, motors shall be approved as specified in Paragraph 6.

## 6. 可靠性測試後期要求 Requirements after Reliability Tests

序號 No.	專案 Items	可靠性測試後期要求 Requirements after Reliability Tests
6-1	額定轉速 Rated Speed	不低於初始值-30%，不高於初始值+30%。 No less than initial data-30%, no more than initial data +30%.
6-2	額定電流 Rated Current	不低於初始值-30%，不高於初始值+30%。 No less than initial data-30%, no more than initial data +30%.
6-3	端阻 Terminal Resistance	不大於初始值±15%。 No more than initial data ±15%.
6-4	起動電壓 Starting Voltage	不大於 2.5V 直流電壓。 2.5V DC Max.
6-5	絕緣電阻 Insulation Resistance	大於 10MΩ。 10MΩ Min.

## 7. 使用時注意事項 Precautions in Use

序號 No.	使用時注意事項 Precautions in Use
7-1	必須按照此產品規格說明書使用，否則性能和壽命都將受到相當地減少。尤其注意電壓的使用範圍。 Please operate the motors in accordance with this specification, especially be careful with the operating voltage ranges, otherwise the performance and lifetime of the motors would be considerably reduced.
7-2	建議馬達收貨後六個月內必須使用。不可以在以下環境中使用及保存馬達： <ul style="list-style-type: none"> <li>◇ 高溫高濕區域；</li> <li>◇ 腐蝕性氣體環境，如：H<sub>2</sub>S、SO<sub>2</sub>、NO<sub>2</sub>、Cl<sub>2</sub>，等等；</li> <li>◇ 易導致金屬物生銹場所。</li> </ul> It is suggested to use the motors within 6 months after delivery. It is not allowed to use or store the motors at such environments: <ul style="list-style-type: none"> <li>◇ High damp and high temperature areas.</li> <li>◇ Places full of corrosive gas, such as H<sub>2</sub>S, SO<sub>2</sub>, NO<sub>2</sub>, Cl<sub>2</sub>, etc.</li> <li>◇ Areas that easily cause metals rusty.</li> </ul>
7-3	注意清潔工作環境，避免含鐵質雜物被馬達吸進，否則馬達將會產生雜訊，性能會受影響，從而降低產品可靠性。 Please pay much attention to clean the working environment, to avoid iron sundries from being sucked into the motors; otherwise, the motors would make noise, the performance would be affected, and reliability would be reduced.
7-4	拿馬達時，要輕拿輕放。不允許隨意丟置。 Please place the motors gently and carefully in use. It is not allowed to throw it at random.
7-5	機殼鋼板面或邊緣有少許鏽斑是允許的。 It is allowed to have a little rust on the brim of steel plate of the housing.
7-6	因為測試設備可能有誤差，所以±5%的轉動頻率偏差是允許的。 It is allowed to have a tolerance of ±5% rotation frequency due to discrepancies between different testing equipments.
7-7	用戶自身應確信使用本產品不會與相關標準、法律、政令相背。 Users shall assure themselves that they do not violate related standards, laws or any political policies when they use this product.

## 8. 外形圖 Outline Drawing

### 8-1 安裝尺寸 Dimensions

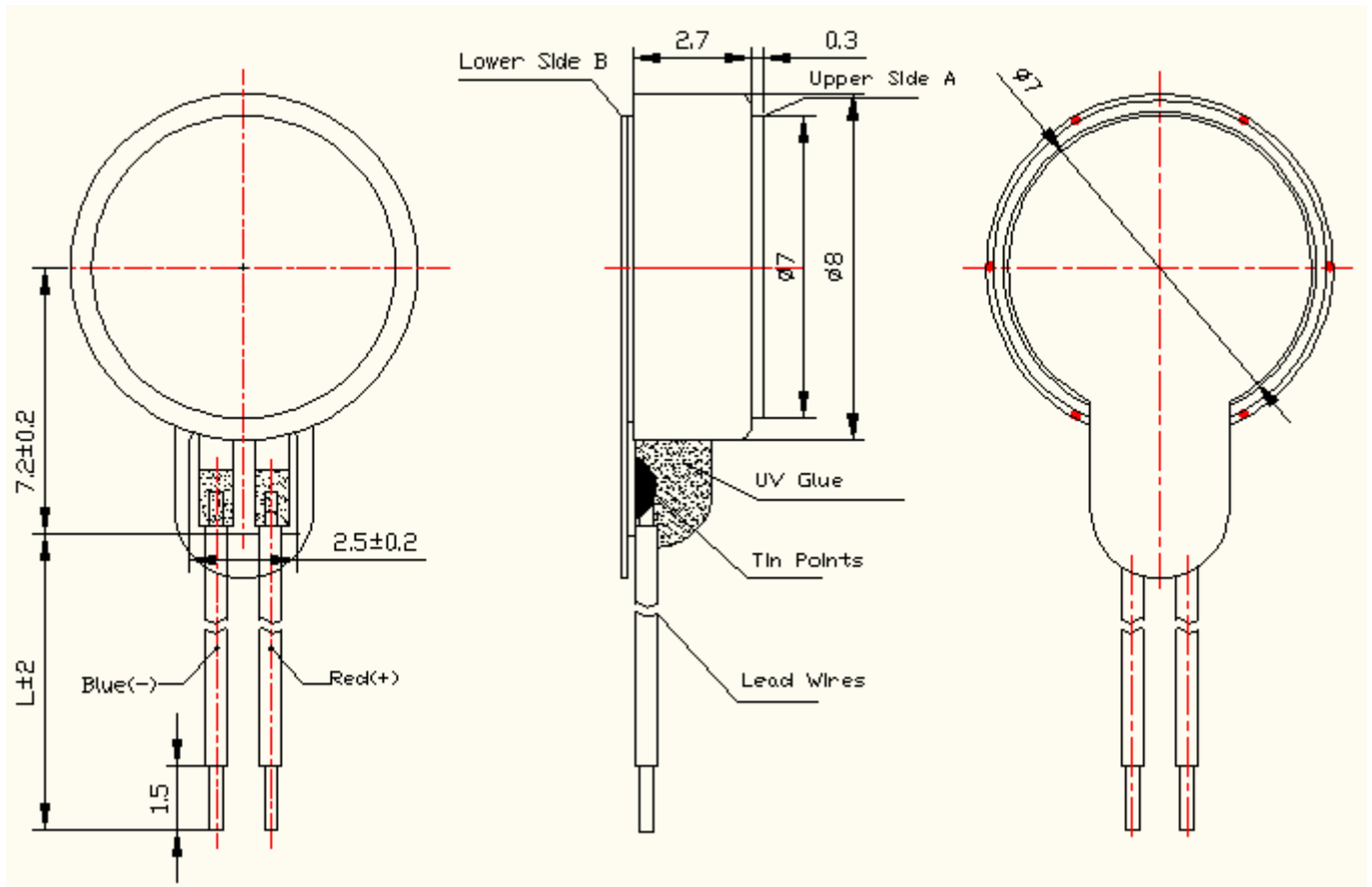

### 8-2 相關材料說明 Specification of Related Materials

- 1) 上貼片 - 單面有膠泡棉, 厚度 0.3mm / Upper Side A - Single-sided adhesive sponge, thickness = 0.3mm.
- 2) 下貼片 - 雙面有膠貼片, 厚度 0.15mm / Lower Side B - Double-sided adhesive tape, thickness = 0.15mm.
- 3) 導線長度 Length of lead wires: L=27mm

### 8-3 其他說明 Other Remarks

- 1) 單位: 毫米。Unit: mm.
- 2) 未注尺寸公差: ±0.1。Unmarked tolerance: ±0.1.
- 3) 上、下貼片可根據客人要求增加厚度或去掉。導線長短可根據客人要求調整。導線末端可加裝連接器。具體要求請在打樣前協商。 / The adhesive sponge or adhesive tape could be removed. Thicknesses could be increased. Length of the lead wires could be adjusted. Connectors could be added to the lead wires. Please negotiate before making samples for any specific requirements.

## 9. 包裝說明 Packaging

### 9-1 包裝說明圖例 Packaging Method

#### 扁平振动马达包装说明图例

#### Packaging Method of Coin Type Vibration Motors

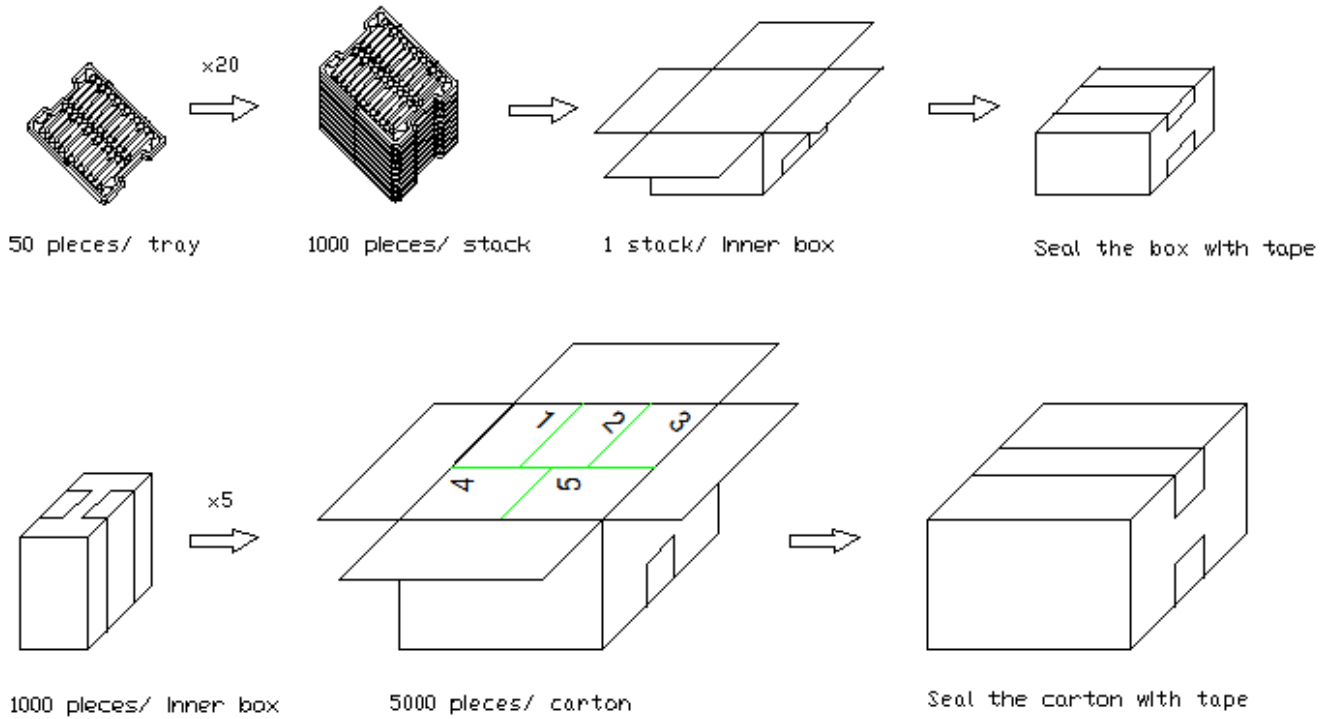

### 9-2 包裝實驗要求 Test Requirements on Packaging:

沿外包裝箱±X、±Y 和±Z 方向，距水泥地面 1.5 米高度，各自由跌落兩次，馬達應無機械損傷，電氣性能仍符合規格要求。

Drop the carton from a height of 1.5 meters twice in each direction of ±x, ±y, and ±z. After dropping, motors shall have no mechanical damages. Electrical performance shall meet the specifications.

### 9-3 包裝明細說明 Packaging Details:

每箱數量 (只) Qty/ Carton (PCS)	紙箱尺寸: 長/寬/高 (釐米) Size of Carton: L*W*H (CM)	淨重 (公斤) Net Weight (KGS)	毛重 (公斤) Gross Weight (KGS)
5,000	36*29*21	4.0	5.0



### 10. 變更記錄表Record of Changes

序號 No.	日期 Date	變更前 Before Change	版本 Version	變更後 After Change	版本 Version	備註 Remark
1	2012-05-14	/	A	/	A	初版發行 Initial Release
2						
3						
4						
5						
6						
7						
8						
9						
10						
11						
12						
13						
14						
15						
16						
17						
18						
19						
20						
...						