

AH-0715

Combination Smoke and Heat Detector

Characteristics

- Magnetic test feature makes maintenance easy and simple.
- Twin-color LED display enables viewer to easily identify the current status of detector.
- The standard detector is 2-wire or 3-wire. For 4-wire type just add one relay output module on 3-wire base. Simple and easy module placement enables wider application and flexible stock control.
- Detector is made of high endurance, solid and colorfast Fire-proof plastic.
- Non-loosening screws on base terminal for easy installation.
- Detector has passed strict EMC test, which greatly eliminates false alarms caused by interference from nearby sources.

Approvals: 

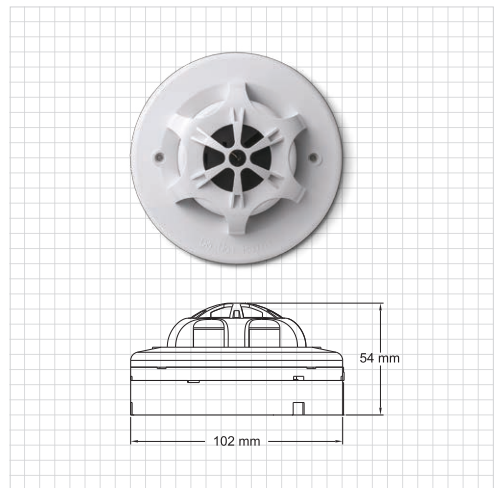

Specifications			
Model	AH-0715-2	AH-0715-3	AH-0715-4
Alarm Contact	N/A	N/A	0.8A @30V DC 0.4A @125V AC
Voltage Range	12 ~ 30V DC		
Alarm Current @24V DC 470Ω	40mA	40mA	45mA
Standby Current	35 ~ 85μA		
Sensitivity Setting	Comply to EN54		
Thermal Setting	58°C		
Ambient Temperature	-10°C ~ +55°C		
Material	Fire-proof plastic		
Dimensions	102mm(Dia.) x 54mm(H)		
Weight	130g	130g	145g
Color	White		

Effective alert area	
Building Height	Area Covered
Under 4M	150 M ²
4 ~ 20M	75 M ²

Order information	
AH-0715-2	2-wire
AH-0715-3	3-wire with remote indicator output
AH-0715-4	4-wire with relay output
AH-0715-2M	2-wire + magnetic test feature
AH-0715-3M	3-wire with remote indicator output + magnetic test feature
AH-0715-4M	4-wire with relay output + magnetic test feature