

(PACKING) FLANGE END NON-RISING STEM GATE VALVE DIN3352, PN10

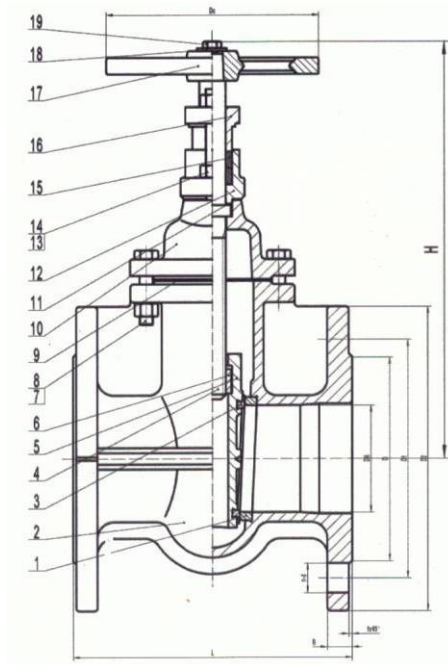

Technical Requirement:

Design, manufacture conforms to DIN 3352.

Face to face dimension conform to Series 14 of BS EN 558-1.

Flange drilled conforms to BS EN1092.

MATERIAL LIST

NO	Name of part	material	Germany standard
19	bolt	steel	DIN17100 RSt37-2
18	washer	steel	DIN17100 RSt37-2
17	handwheel	cast iron	DIN1691 GG25
16	gland follower	ductile iron	DIN1693 GGG50
15	packing	graphite	
14	nut	steel	DIN17100 RSt37-2
13	bolt	steel	DIN17100 RSt37-2
12	stuffing box	ductile iron	DIN1693 GGG50
11	stuffing box gasket	rubber graphite	
10	bonnet	cast iron	DIN1691 GG25
9	flange gasket	graphite	
8	nut	steel	DIN17100 RSt37-2
7	bolt	steel	DIN17100 RSt37-2
6	stem nut	cast brass	
5	wedge	cast iron	DIN1691 GG25
4	stem	stainless steel	DIN17440 X20Cr13
3	wedge seat ring	cast brass	DIN17656
2	body	cast iron	DIN1691 GG25
1	body seat ring	cast brass	DIN17656

SCOPE OF APPLICATION

Nominal Pressure		1.0MPa
suitable medium		water, oil, steam
test pressure	sheel	1.5MPa
	seat	1.1MPa
test time	60s	
working pressure	120°C	1.0MPa

DIMENSIONS(MM)

DN	L	D	D1	D2	B	f	n-d	Do	H
40	140	150	110	80	16	2	4-19	130	245
50	150	165	125	102	16	2	4-19	130	255
65	170	185	145	124	16	2	4-19	130	277
80	180	200	160	140	17	2	8-19	150	303
100	190	220	180	158	17	2	8-19	185	340
125	200	250	210	188	18	3	8-19	185	387
150	210	285	240	212	20	3	8-23	195	454
200	230	340	295	268	21	3	8-23	225	538
250	250	395	350	320	23	3	12-23	245	629
300	270	445	400	370	24	4	12-23	285	730

E-MAIL: nancygao@public.qd.sd.cn
nancygao@bdchina.com

TEL: 0086/532/66753307 OR 013953280182
 FAX: 0086/532/66753309 OR 85791651