

TUNGSTEN CARBIDE RODS

➤ Our advantages:

Advanced extrusion and mold pressing technology, innovative products, and grade development, along with the high level of training of our employees and extensive automation enable us to offer you substantial price-performance advantages for high performance carbides. While focusing on coolant-fed rods for the cutting tool industry, our service and expertise go beyond just offering carbide!

➤ Fields of business

- Cutting Tool Industry
- PCB Tools
- Dies / Punches
- Blades
- Paper Industry
- Polymer Extrusion
- Gear Cutting
- Other Wear Parts

➤ Carbide Grades

GRADE	ISO CODE	COBALT CONTENT	DENSITY	HARDNESS	TRS
		(%)	g/cm ³	HRA	N/mm ²
K10T	K05-K10	4.5-6.0	14.95-15.05	92.7	1800
YG8	K30	8	14.80	89.5	2200
YG6	K20	6	14.95	90.5	1900
YG6X	K10	6	14.95	91.5	1800
YL10.2	K30	10	14.50	91.8	2400
YG13X	K30-K40	13	14.30	89.5	2600
YG15	K40	15	14.00	87.5	2800
EK12	K20-K30	10	14.5	91.8	4000
EK14	K40-K50	12	14.1	92.5	4000
EK16	K05-K10	6	14.8	94.3	3800
EK16-1	K05	6	14.9	91.5	3400
EYL50	K30-K40	15	14	87.6	4000

➤ Product Informations

Solid Rods

Rod, unground, without coolant hole

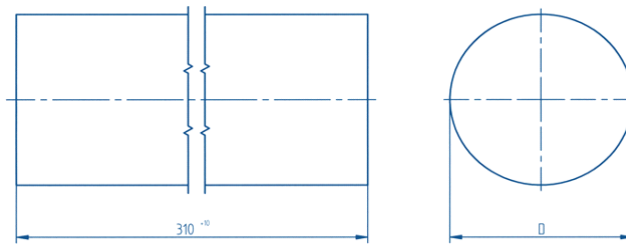

- Length: 310 mm

D [mm]	TOL [mm]	D [mm]	TOL [mm]
1.2	+ 0.20	16.7	+ 0.50
1.7	+ 0.20	17.2	+ 0.50
2.2	+ 0.20	17.7	+ 0.50
2.7	+ 0.20	18.2	+ 0.60
3.2	+ 0.20	18.7	+ 0.60
3.7	+ 0.20	19.2	+ 0.60

D [mm]	TOL [mm]	D [mm]	TOL [mm]
4.2	+ 0.20	19.7	+ 0.60
4.7	+ 0.20	20.2	+ 0.60
5.2	+ 0.20	20.7	+ 0.60
5.7	+ 0.25	21.2	+ 0.60
6.2	+ 0.25	21.7	+ 0.60
6.7	+ 0.25	22.2	+ 0.60
7.2	+ 0.25	22.7	+ 0.60
7.7	+ 0.25	23.2	+ 0.60
8.2	+ 0.30	23.7	+ 0.60
8.7	+ 0.30	24.2	+ 0.70
9.2	+ 0.30	25.2	+ 0.70
9.7	+ 0.30	25.7	+ 0.70
10.2	+ 0.30	26.2	+ 0.70
10.7	+ 0.30	27.2	+ 0.70
11.2	+ 0.35	28.2	+ 0.70
11.7	+ 0.35	29.2	+ 0.70
12.2	+ 0.35	30.2	+ 0.70
12.7	+ 0.45	31.2	+ 0.70
13.2	+ 0.45	32.2	+ 0.70
13.7	+ 0.45	33.2	+ 0.80
14.2	+ 0.50	34.2	+ 0.80
14.7	+ 0.50	35.2	+ 0.80
15.2	+ 0.50	36.2	+ 0.80
15.7	+ 0.50	38.2	+ 0.80
16.2	+ 0.50	40.2	+ 0.80

● Length: 330 mm

D [mm]	TOL [mm]	D [mm]	TOL [mm]
1.2	+ 0.20	15.2	+ 0.50
1.7	+ 0.20	15.7	+ 0.50
2.2	+ 0.20	16.2	+ 0.50
2.7	+ 0.20	16.7	+ 0.50
3.2	+ 0.20	17.2	+ 0.50
3.7	+ 0.20	17.7	+ 0.50
4.2	+ 0.20	18.2	+ 0.60
4.7	+ 0.20	18.7	+ 0.60

D [mm]	TOL [mm]	D [mm]	TOL [mm]
5.2	+ 0.20	19.2	+ 0.60
5.7	+ 0.25	19.7	+ 0.60
6.2	+ 0.25	20.2	+ 0.60
6.7	+ 0.25	20.7	+ 0.60
7.2	+ 0.25	21.2	+ 0.60
7.7	+ 0.25	21.7	+ 0.60
8.2	+ 0.30	22.2	+ 0.60
8.7	+ 0.30	22.7	+ 0.60
9.2	+ 0.30	23.2	+ 0.60
9.7	+ 0.30	23.7	+ 0.60
10.2	+ 0.30	24.2	+ 0.70
10.7	+ 0.30	25.2	+ 0.70
11.2	+ 0.35	25.7	+ 0.70
11.7	+ 0.35	26.2	+ 0.70
12.2	+ 0.35	27.2	+ 0.70
12.7	+ 0.45	28.2	+ 0.70
13.2	+ 0.45	29.2	+ 0.70
13.7	+ 0.45	30.2	+ 0.70
14.2	+ 0.50	31.2	+ 0.70
14.7	+ 0.50	32.2	+ 0.70

One central coolant hole Rods

Rods, unground, with one central coolant hole

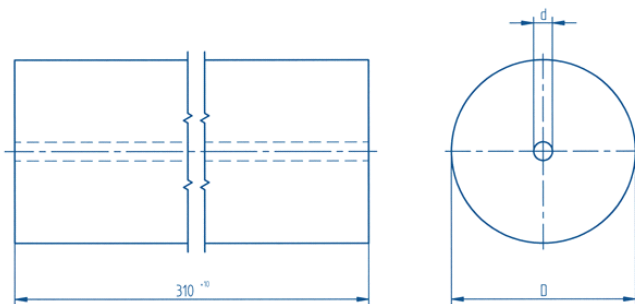

- Length: 310 mm

D	TOL	d	TOL	max. hole center offset
[mm]	[mm]	[mm]	[mm]	[mm]

4.5	+ 0.3	0.60	± 0.10	0.15
6.3	+ 0.3	1.00	± 0.15	0.15
8.3	+ 0.3	1.30	± 0.15	0.15
10.3	+ 0.4	2.00	± 0.20	0.20
12.3	+ 0.4	2.00	± 0.20	0.20
14.3	+ 0.4	2.00	± 0.20	0.30
16.3	+ 0.5	2.00	± 0.20	0.30
18.3	+ 0.5	3.00	± 0.25	0.40
20.3	+ 0.5	3.00	± 0.25	0.50
22.3	+ 0.5	3.00	± 0.25	0.50
24.3	+ 0.5	4.00	± 0.30	0.50
26.3	+ 0.5	4.00	± 0.30	0.50
28.3	+ 0.5	4.00	± 0.30	0.50
30.3	+ 0.5	5.00	± 0.35	0.50
32.3	+ 0.5	5.00	± 0.35	0.50

● Length: 330 mm

D	TOL	d	TOL	max. hole center offset
[mm]	[mm]	[mm]	[mm]	[mm]
4.5	+ 0.3	0.60	± 0.10	0.15
4.501	+ 0.3	1.00	± 0.15	0.15
6.3	+ 0.3	1.00	± 0.15	0.15
6.301	+ 0.3	1.80	± 0.15	0.15
8.3	+ 0.3	1.30	± 0.15	0.15
8.301	+ 0.3	2.50	± 0.15	0.15
8.302	+ 0.3	1.80	± 0.15	0.15
10.3	+ 0.4	2.00	± 0.20	0.20
10.301	+ 0.4	3.00	± 0.20	0.20
12.3	+ 0.4	2.00	± 0.20	0.20
12.301	+ 0.4	3.00	± 0.20	0.20
14.3	+ 0.4	2.00	± 0.20	0.30

14.301	+ 0.4	3.00	± 0.20	0.30
16.3	+ 0.5	2.00	± 0.20	0.30
16.301	+ 0.5	2.50	± 0.20	0.30
16.302	+ 0.5	4.00	± 0.30	0.30
18.3	+ 0.5	3.00	± 0.25	0.40
18.301	+ 0.5	4.00	± 0.25	0.40
20.3	+ 0.5	3.00	± 0.25	0.50
20.301	+ 0.5	4.00	± 0.25	0.50
22.3	+ 0.5	3.00	± 0.25	0.50
24.3	+ 0.5	4.00	± 0.30	0.50
25.3	+ 0.5	4.00	± 0.30	0.50
26.3	+ 0.5	4.00	± 0.30	0.50
28.3	+ 0.5	4.00	± 0.30	0.50
30.3	+ 0.5	5.00	± 0.35	0.50
32.3	+ 0.5	5.00	± 0.35	0.50

Two straight coolant holes Rods

Rods, unground, with 2 straight coolant holes

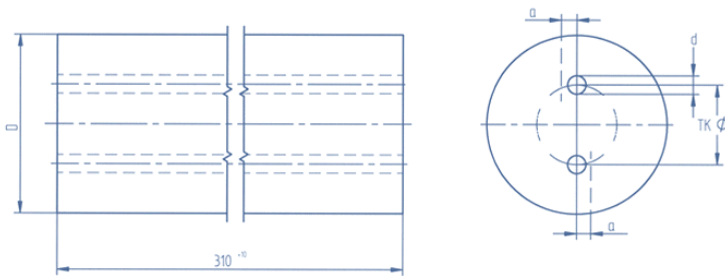

- Length: 310 mm

D	TOL	BC-Ø	TOL	d	TOL	a
[mm]	[mm]	[mm]	[mm]	[mm]	[mm]	[mm]
4.2	+ 0.3	1.80	-0.15	0.80	± 0.10	0.10
5.2	+ 0.3	2.00	-0.15	0.80	± 0.10	0.13
6.3	+ 0.3	3.00	-0.20	1.00	± 0.10	0.15

D	TOL	BC-Ø	TOL	d	TOL	a
[mm]	[mm]	[mm]	[mm]	[mm]	[mm]	[mm]
7.3	+ 0.3	3.50	-0.20	1.00	± 0.15	0.15
8.3	+ 0.3	4.00	-0.30	1.00	± 0.15	0.15
9.3	+ 0.3	4.00	-0.3	1.40	± 0.15	0.20
10.3	+ 0.3	5.00	-0.30	1.40	± 0.15	0.20
11.3	+ 0.4	5.00	-0.30	1.40	± 0.15	0.28
12.3	+ 0.4	6.00	-0.30	1.75	± 0.15	0.30
13.3	+ 0.4	6.00	-0.30	1.75	± 0.15	0.34
14.3	+ 0.4	7.00	-0.30	1.75	± 0.15	0.37
15.3	+ 0.4	7.00	-0.30	2.00	± 0.20	0.40
16.3	+ 0.4	8.00	-0.30	2.00	± 0.20	0.40
17.3	+ 0.5	8.00	-0.30	2.00	± 0.20	0.47
18.3	+ 0.5	9.00	-0.30	2.00	± 0.20	0.50
19.3	+ 0.5	9.00	-0.30	2.00	± 0.20	0.50
20.4	+ 0.5	10.00	-0.40	2.50	± 0.25	0.50
21.4	+ 0.5	10.00	-0.40	2.50	± 0.25	0.50
22.4	+ 0.5	11.00	-0.40	2.50	± 0.25	0.50
23.4	+ 0.5	11.00	-0.40	2.50	± 0.25	0.50
24.4	+ 0.5	12.00	-0.50	3.00	± 0.25	0.50
25.4	+ 0.5	12.00	-0.50	3.00	± 0.25	0.50
26.4	+ 0.5	13.00	-0.50	3.00	± 0.25	0.50
28.4	+ 0.5	14.00	-0.50	3.00	± 0.25	0.50
30.4	+ 0.5	14.00	-0.50	3.00	± 0.25	0.5
32.4	+ 0.5	14.00	-0.50	3.00	± 0.25	0.50
34.4	+ 0.5	14.00	-0.50	3.00	± 0.25	0.50

● Length 330 mm

D	TOL	BC-Ø	TOL	d	TOL	a
[mm]	[mm]	[mm]	[mm]	[mm]	[mm]	[mm]
4.2	+ 0.3	1.80	-0.15	0.80	± 0.10	0.10

D	TOL	BC-Ø	TOL	d	TOL	a
[mm]	[mm]	[mm]	[mm]	[mm]	[mm]	[mm]
5.2	+ 0.3	2.00	-0.15	0.80	± 0.10	0.13
6.3	+ 0.3	3.00	-0.20	1.00	± 0.10	0.15
7.3	+ 0.3	3.50	-0.20	1.00	± 0.15	0.15
8.3	+ 0.3	4.00	-0.30	1.00	± 0.15	0.15
9.3	+ 0.3	4.00	-0.3	1.40	± 0.15	0.20
10.3	+ 0.3	5.00	-0.30	1.40	± 0.15	0.20
11.3	+ 0.4	5.00	-0.30	1.40	± 0.15	0.28
12.3	+ 0.4	6.00	-0.30	1.75	± 0.15	0.30
13.3	+ 0.4	6.00	-0.30	1.75	± 0.15	0.34
14.3	+ 0.4	7.00	-0.30	1.75	± 0.15	0.37
15.3	+ 0.4	7.00	-0.30	2.00	± 0.20	0.40
16.3	+ 0.4	8.00	-0.30	2.00	± 0.20	0.40
17.3	+ 0.5	8.00	-0.30	2.00	± 0.20	0.47
18.3	+ 0.5	9.00	-0.30	2.00	± 0.20	0.50
19.3	+ 0.5	9.00	-0.30	2.00	± 0.20	0.50
20.4	+ 0.5	10.00	-0.40	2.50	± 0.25	0.50
21.4	+ 0.5	10.00	-0.40	2.50	± 0.25	0.50
22.4	+ 0.5	11.00	-0.40	2.50	± 0.25	0.50
23.4	+ 0.5	11.00	-0.40	2.50	± 0.25	0.50
24.4	+ 0.5	12.00	-0.50	3.00	± 0.25	0.50
25.4	+ 0.5	12.00	-0.50	3.00	± 0.25	0.50
26.4	+ 0.5	13.00	-0.50	3.00	± 0.25	0.50

Two 30° twisted coolant ducts Rods

Rods, unground, with 2 straight coolant ducts, 30° helix

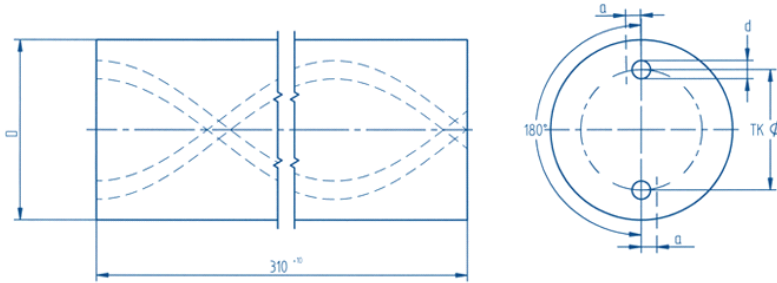

- Length: 310 mm

D	TOL	BC-Ø	TOL	d	TOL	a	Pitch at 30° ± 0.5°
[mm]	[mm]	[mm]	[mm]	[mm]	[mm]	[mm]	[mm]
3.3	+ 0.3	1.70	-0.2	0.40	± 0.10	0.08	16.32
3.8	+ 0.3	1.90	-0.2	0.50	± 0.10	0.09	19.04
4.3	+ 0.3	2.20	-0.2	0.60	± 0.10	0.10	21.77
4.8	+ 0.3	2.40	-0.3	0.70	± 0.10	0.10	24.49
5.3	+ 0.3	2.60	-0.4	0.70	± 0.10	0.13	27.21
5.8	+ 0.3	2.60	-0.4	0.70	± 0.10	0.14	29.93
6.3	+ 0.3	2.60	-0.4	0.70	± 0.10	0.15	32.65
6.8	+ 0.3	3.50	-0.4	1.00	± 0.15	0.15	35.37
7.3	+ 0.3	3.70	-0.4	1.00	± 0.15	0.15	38.09
7.8	+ 0.3	4.00	-0.4	1.00	± 0.15	0.15	40.81
8.3	+ 0.3	4.00	-0.4	1.00	± 0.15	0.15	43.53
8.8	+ 0.3	4.50	-0.6	1.00	± 0.15	0.20	46.25
9.3	+ 0.3	4.80	-0.6	1.40	± 0.15	0.20	48.97
9.8	+ 0.3	4.80	-0.6	1.40	± 0.15	0.20	51.69
10.3	+ 0.3	4.80	-0.6	1.40	± 0.15	0.20	54.41
10.8	+ 0.4	4.80	-0.8	1.40	± 0.15	0.28	57.13
11.3	+ 0.4	5.30	-0.8	1.40	± 0.15	0.28	59.86
11.8	+ 0.4	5.80	-0.8	1.40	± 0.15	0.30	62.58
12.3	+ 0.4	6.25	-0.8	1.40	± 0.15	0.30	65.30
12.8	+ 0.4	6.25	-0.8	1.75	± 0.20	0.33	68.02
13.3	+ 0.4	6.50	-0.8	1.75	± 0.20	0.34	70.74
13.8	+ 0.4	6.80	-0.8	1.75	± 0.20	0.35	73.46
14.3	+ 0.4	7.10	-0.8	1.75	± 0.20	0.37	76.18
14.8	+ 0.4	7.40	-0.8	1.75	± 0.20	0.39	78.90

D	TOL	BC-Ø	TOL	d	TOL	a	Pitch at 30° ± 0.5°
[mm]	[mm]	[mm]	[mm]	[mm]	[mm]	[mm]	[mm]
15.3	+ 0.4	7.70	-0.8	1.75	± 0.20	0.40	81.62
15.8	+ 0.4	8.00	-0.8	1.75	± 0.20	0.40	84.34
16.3	+ 0.4	8.30	-0.8	1.75	± 0.20	0.40	87.06
16.8	+ 0.5	8.60	-0.8	1.75	± 0.20	0.45	89.78
17.3	+ 0.5	8.90	-0.8	1.75	± 0.20	0.47	92.50
17.8	+ 0.5	9.20	-0.8	1.75	± 0.20	0.48	95.22
18.3	+ 0.5	9.55	-0.8	2.00	± 0.25	0.50	97.95
18.8	+ 0.5	9.75	-0.8	2.00	± 0.25	0.50	100.67
19.3	+ 0.5	10.10	-0.8	2.00	± 0.25	0.50	103.39
19.8	+ 0.5	10.25	-1.0	2.00	± 0.25	0.50	106.10
20.3	+ 0.5	10.40	-1.0	2.00	± 0.25	0.50	108.83
21.3	+ 0.5	11.15	-1.0	2.00	± 0.25	0.50	114.27
22.3	+ 0.5	11.60	-1.0	2.00	± 0.25	0.50	119.71
23.3	+ 0.5	12.20	-1.0	2.00	± 0.25	0.50	125.15
24.3	+ 0.5	12.80	-1.0	2.00	± 0.25	0.50	130.59
25.3	+ 0.5	13.30	-1.0	2.00	± 0.25	0.50	136.03
26.3	+ 0.5	13.80	-1.0	2.00	± 0.25	0.50	141.48
27.3	+ 0.5	14.30	-1.2	2.50	± 0.30	0.60	146.92
28.3	+ 0.5	14.80	-1.2	2.50	± 0.30	0.60	152.36
29.3	+ 0.5	15.40	-1.2	2.50	± 0.30	0.60	157.80
30.3	+ 0.5	16.00	-1.2	2.50	± 0.3	0.70	163.24
31.3	+ 0.5	16.60	-1.2	2.50	± 0.30	0.70	168.68
32.3	+ 0.5	17.20	-1.2	3.00	± 0.30	0.80	174.12
33.3	+ 0.5	17.80	-1.2	3.00	± 0.30	0.80	179.57
34.3	+ 0.5	18.00	-1.2	3.00	± 0.30	0.80	185.01
35.3	+ 0.5	18.00	-1.2	3.00	± 0.30	0.80	190.45

● Length: 330 mm

D	TOL	BC-Ø	TOL	d	TOL	a	Pitch at 30° ± 0.5°
[mm]	[mm]	[mm]	[mm]	[mm]	[mm]	[mm]	[mm]
3.3	+ 0.3	1.70	-0.2	0.40	± 0.10	0.08	16.32
3.8	+ 0.3	1.90	-0.2	0.50	± 0.10	0.09	19.04
4.3	+ 0.3	2.20	-0.2	0.60	± 0.10	0.10	21.77
4.8	+ 0.3	2.40	-0.3	0.70	± 0.10	0.10	24.49
5.3	+ 0.3	2.60	-0.4	0.70	± 0.10	0.13	27.21

D	TOL	BC-Ø	TOL	d	TOL	a	Pitch at 30° ± 0.5°
[mm]	[mm]	[mm]	[mm]	[mm]	[mm]	[mm]	[mm]
5.8	+ 0.3	2.60	-0.4	0.70	± 0.10	0.14	29.93
6.3	+ 0.3	2.60	-0.4	0.70	± 0.10	0.15	32.65
6.8	+ 0.3	3.50	-0.4	1.00	± 0.15	0.15	35.37
7.3	+ 0.3	3.70	-0.4	1.00	± 0.15	0.15	38.09
7.8	+ 0.3	4.00	-0.4	1.00	± 0.15	0.15	40.81
8.3	+ 0.3	4.00	-0.4	1.00	± 0.15	0.15	43.53
8.8	+ 0.3	4.50	-0.6	1.00	± 0.15	0.20	46.25
9.3	+ 0.3	4.80	-0.6	1.40	± 0.15	0.20	48.97
9.8	+ 0.3	4.80	-0.6	1.40	± 0.15	0.20	51.69
10.3	+ 0.3	4.80	-0.6	1.40	± 0.15	0.20	54.41
10.8	+ 0.4	4.80	-0.8	1.40	± 0.15	0.28	57.13
11.3	+ 0.4	5.30	-0.8	1.40	± 0.15	0.28	59.86
11.8	+ 0.4	5.80	-0.8	1.40	± 0.15	0.30	62.58
12.3	+ 0.4	6.25	-0.8	1.40	± 0.15	0.30	65.30
12.8	+ 0.4	6.25	-0.8	1.75	± 0.20	0.33	68.02
13.3	+ 0.4	6.50	-0.8	1.75	± 0.20	0.34	70.74
13.8	+ 0.4	6.80	-0.8	1.75	± 0.20	0.35	73.46
14.3	+ 0.4	7.10	-0.8	1.75	± 0.20	0.37	76.18
15.3	+ 0.4	7.70	-0.8	1.75	± 0.20	0.40	81.62
16.3	+ 0.4	8.30	-0.8	1.75	± 0.20	0.40	87.06
16.8	+ 0.5	8.60	-0.8	1.75	± 0.20	0.45	89.78
17.3	+ 0.5	8.90	-0.8	1.75	± 0.20	0.47	92.50
18.3	+ 0.5	9.55	-0.8	2.00	± 0.25	0.50	97.95
18.8	+ 0.5	9.75	-0.8	2.00	± 0.25	0.50	100.67
19.3	+ 0.5	10.10	-0.8	2.00	± 0.25	0.50	103.39
20.3	+ 0.5	10.40	-1.0	2.00	± 0.25	0.50	108.83
21.3	+ 0.5	11.15	-1.0	2.00	± 0.25	0.50	114.27
22.3	+ 0.5	11.60	-1.0	2.00	± 0.25	0.50	119.71
23.3	+ 0.5	12.20	-1.0	2.00	± 0.25	0.50	125.15
24.3	+ 0.5	12.80	-1.0	2.00	± 0.25	0.50	130.59
25.3	+ 0.5	13.30	-1.0	2.00	± 0.25	0.50	136.03
26.3	+ 0.5	13.80	-1.0	2.00	± 0.25	0.50	141.48
27.3	+ 0.5	14.30	-1.2	2.50	± 0.30	0.60	146.92
28.3	+ 0.5	14.80	-1.2	2.50	± 0.30	0.60	152.36
29.3	+ 0.5	15.40	-1.2	2.50	± 0.30	0.60	157.80
30.3	+ 0.5	16.00	-1.2	2.50	± 0.3	0.70	163.24
31.3	+ 0.5	16.60	-1.2	2.50	± 0.30	0.70	168.68
32.3	+ 0.5	17.20	-1.2	3.00	± 0.30	0.80	174.12

D	TOL	BC-Ø	TOL	d	TOL	a	Pitch at 30° ± 0.5°
[mm]	[mm]	[mm]	[mm]	[mm]	[mm]	[mm]	[mm]
34.3	+ 0.5	18.00	-1.2	3.00	± 0.30	0.80	185.01
35.3	+ 0.5	18.00	-1.2	3.00	± 0.30	0.80	190.45

Precision Rods

TYPE	D	L		TYPE	D	L
Φ1.0×100	1.0	100		Φ5.0×50	5.0	50
Φ1.5×100	1.5	100		Φ5.0×100	5.0	100
Φ2.0×100	2.0	100		Φ5.5×100	5.5	100
Φ2.35×38.5	2.35	38.5		Φ6.5×100	6.5	100
Φ2.35×50	2.35	50		Φ7.0×100	7.0	100
Φ2.5×100	2.5	100		Φ7.5×100	7.5	100
Φ3×38.5	3.0	38.5		Φ8.0×100	8.0	100
Φ3×45	3.0	45		Φ9.0×100	9.0	100
Φ3×50	3.0	50		Φ10.0×100	10.0	100
Φ3×60	3.0	60		Φ11.0×100	11.0	100
Φ3×70	3.0	70		Φ12.0×100	12.0	100
Φ3×100	3.0	100		Φ13.0×100	13.0	100
Φ3.5×100	3.5	100		Φ14.0×100	14.0	100
Φ4.0×40	4.0	40		Φ15.0×100	15.0	100
Φ4.0×50	4.0	50		Φ16.0×100	16.0	100
Φ4.0×100	4.0	100		Φ18.0×100	18.0	100
Φ4.5×100	4.5	100		Φ20.0×100	20.0	100
Φ5.0×100	5.0	100				

Notes:

- 1) Above are our standard sizes of carbide rods, but we are capable of satisfying all of your special carbide needs
- 2) If you can not find carbide rods you requested from above list, please provide your specification of carbide rods, we will make them upon it.
- 3) Regarding two twisted coolant ducts rods, besides of 30° and 40° twisted angles, we also can provide 15 °, 40 ° or 45 ° optional angles.