

AHS-871

Photoelectric Smoke Detector

Characteristics

- Detector has a monitoring LED that operates about every 16 seconds (flash) during standby status. When there is smoke, the detector will issue fire signal after 16 consecutive confirmations. (every 0.3 second) If any dust causes flashing or an intermittent signal, it will return to normal status after 32 confirmations.
- The coating of terminal contacts meets the Rohs and provides better results on corrosion and conductive.
- Each detector has added specific components that will effectively isolate interference from electromagnetic fields and lightning strike.
- All detectors use high-density steel for the contacting plate material.

Approvals: EN54

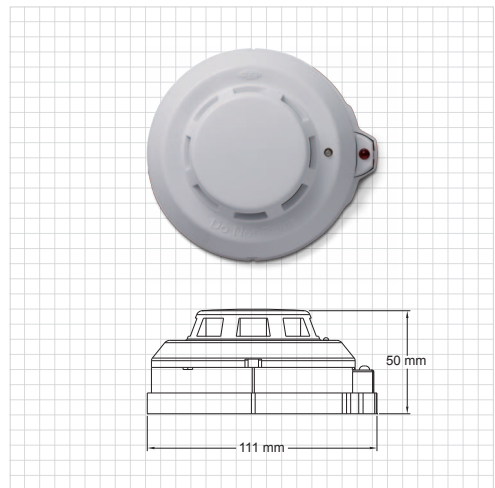

Specifications			
Model	AHS-871		
Type	2-wire	3-wire	4-wire
Alarm Contact	N/A	N/A	0.8A @30V DC 0.4A @125V AC
Voltage Range	12 ~ 30V DC		
Alarm Current	Max.30mA		
Standby Current	20 ~ 30µA (Loop response under 75µA)		
Sensitivity Setting	Comply to EN 54		
Ambient Temperature	-10°C ~ +55°C		
Material	Fire-proof plastic		
Dimensions	111mm(Dia.) x 50mm(H)		
Weight	About 170g		
Color	White		

Effective alert area	
Building Height	Area Covered
Under 4M	150 M ²
4 ~ 20M	75 M ²