

NQ9S

Single Station Smoke Detector

Characteristics

- New design on minified chamber makes so easy for maintenance.
- High luminous LED for light guiding design.
- Detector has passed strict EMC test, which greatly eliminates false alarms caused by interference from nearby sources.
- Simple test method: Press test button to hear the alarm sound and confirm the unit is in normal condition.
- Easy installation: Install directly to proper location without any wiring.
- It is equipped with 9VDC battery, and optional 100~240VAC power plug is available.
- Optional relay output : COM. NO. NC.
- Optional series connection wiring can co-activate up to 20 detectors.

Approvals: EN14604

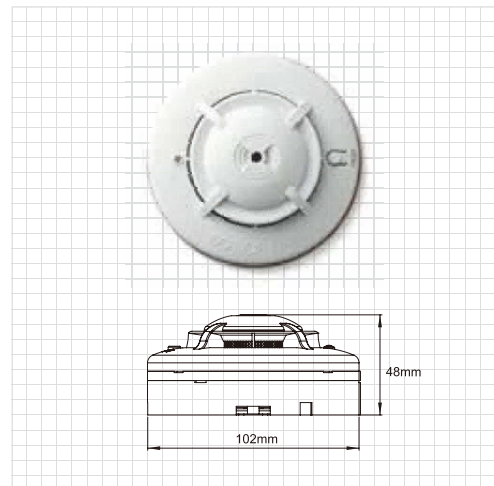

Specifications

Model	NQ9S
Power	9V battery
Sensitivity Setting	Comply to EN14604
Indicator	Standby: flash every 45 seconds
	Alarm: flash and beep continuously
	Battery abnormal: beeps and flash intermittently
Sound	90dB / M and above
Ambient Temperature	-10°C ~ +55°C
Material	Fire-proof plastic
Dimensions	102mm(Dia.) x 48mm(H)
Weight	About 165g
Color	White
Optional Function	Type 1 : 9V battery
	Type 2 : includes signal transfer COM. N.O. N.C.
	Type 3 : Type 2 + Type 4
	Type 4 : build-in 110VAC or 220VAC plug

Effective alert area

Building Height	Area Covered
Under 4M	150 M ²
4 ~ 20M	75 M ²