

CPD系列四支点平衡重电动叉车

CPD Series 4-Wheel Electric Counterbalanced Forklift

主要特点 Main character

- | | |
|---|--|
| <ul style="list-style-type: none"> 1、重型设计，结构紧凑合理 2、制动灵活安全可靠，行动快捷有力 3、适合中小货场、仓库作业 | <ul style="list-style-type: none"> 1.It's heavy-duty designed,has compact and reasonable structure 2.It acts quickly and powerful with flexible and reliable brake 3.It's suitable for working in warehouse and goods field |
|---|--|

可选配置 Optional



可安装侧移
Side Shift

CPDQA

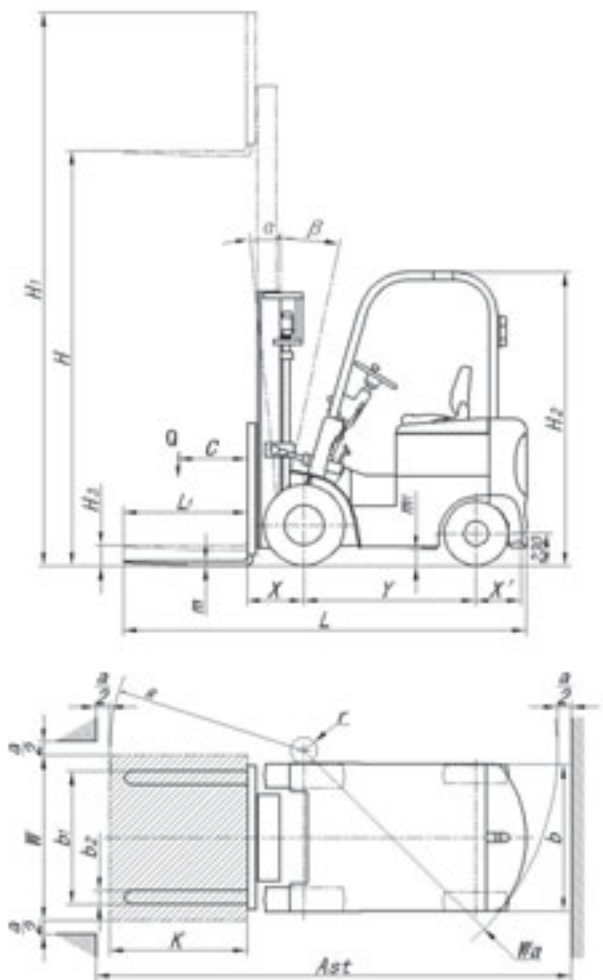

CPDQA

技术参数 Technical data

特性 Identification	产品型号 Product Model designation		CPD15QA		
	驱动形式 Drive Unit		电动 Electric		
	驾驶方式 Operation type		座驾式 Seated		
	额定载重 Load capacity	Q kg	1500		
	载荷中心 Load center	C mm	500		
基本尺寸 Dimension	总长 Overall length	L mm	2937		
	车体宽度 Overall width	b mm	1070		
	总高 Overall height	H2 mm	2140		
	起升高度 Lift height	H mm	3000	4500	
	作业时最大高度 Max working height	H1 mm	4030	5530	
	自由提升高度 Free lift height	H3 mm	150	1135	
	货叉尺寸 Fork dimensions	L1 x b2 x m mm	900 x 100 x 35		
	货叉外宽 Maximum fork width	b1 mm	200~950可调 (Adjustable)		
	最小离地间隙 Minimum ground clearance	m1 mm	110		
	最小直角通道 Min. right angle aisle width	mm	1950		
	最小堆垛通道 Min. aisle width for stacking	Ast mm	3500 (for pallet 1200 x 1000)		
	门架倾角 Mast obliquity	α/β °	6/12	3/6	
	轴距 Wheelbase	Y mm	1250		
	前悬距 Front overhang	X mm	417	432	
	后悬距 Rear overhang	X' mm	332		
	转弯半径 Turning radius	Wa mm	1850		
性能 Performance	行驶速度 Travel speed	满载 Loaded	Km/h	13	
		空载 Unloaded	Km/h	15	
	提升速度 Lift speed	满载 Loaded	mm/s	300	230
		空载 Unloaded	mm/s	400	310
	下降速度 Lowering speed	满载 Loaded	mm/s	400	
		空载 Unloaded	mm/s	385	
爬坡能力 Gradeability(Loaded/Unloaded)	%	15/20			
制动方式 Brake type		液压制动 Hydraulic			
电机 Electric Motor	驱动电机功率 Drive motor power	KW	5		
	提升电机功率 Lift motor power	KW	6.3		
	转向电机 Turning motor power	KW	0.75		
	蓄电池容量/电压 Battery capacity/voltage	Ah/V	400/48		
重量 Weight	自重(不含电池) Weight without battery	kg	3100	3200	
	电池重量 Battery weight	kg	750		