



60W Dual Output Switching Power Supply

60W SERIES

Features:

- * Universal AC input /Full range
- * High efficiency and high reliability
- * Built in EMI filter.low ripple noise
- * Protections: Short circuit / Overload / Over voltage
- * Output voltage $\pm 10\%$ adjustment
- * Cooling by free air convection
- * 100% full load burn-in test
- * 2 years warranty
- * Meet UL,CB,CE



SPECIFICATION

MODEL		3H-602XX01		3H-602XX02	
OUTPUT	OUTPUT NUMBER	CH1	CH2	CH1	CH2
	DC VOLTAGE	5V	12V	5V	24V
	RATED CURRENT	4.8A	3A	4.8A	1.5A
	CURRENT RANGE	0.3~6A	0.3~4A	0.3~6A	0.25~2.2A
	RATED POWER	60W		60W	
	RIPPLE & NOISE <small>Note.2</small>	80mVp-p	120mVp-p	80mVp-p	240mVp-p
	VOLTAGE ADJ. RANGE	CH1 4.75V~5.5V		CH1 4.75V~5.5V	
	VOLTAGE TOLERANCE <small>Note.3</small>	$\pm 5\%$	$\pm 5\%$	$\pm 5\%$	$\pm 6\%$
	LINE REGULATION	$\pm 1\%$	$\pm 1\%$	$\pm 1\%$	$\pm 1\%$
	LOAD REGULATION	$\pm 5\%$	$\pm 5\%$	$\pm 5\%$	$\pm 5\%$
	SETUP TIME	1000ms/230VAC ; 2000ms/115VAC at full load			
RISE TIME	50mS MAX.				
HOLD UP TIME	50ms/230VAC ; 10ms/115VAC at full load				
INPUT	VOLTAGE RANGE	85 ~ 264VAC ; 120 ~ 370VDC			
	FREQUENCY RANGE	47~63Hz			
	EFFICIENCY	79%		80%	
	AC CURRENT	1.4A/115VAC ; 0.7A/230VAC			
	INRUSH CURRENT	COLD START 30A/115VAC ; 60A/230VAC			
	LEAKAGE CURRENT	<3.5mA /240VAC			
PROTECTION	OVER LOAD	110~160% rated output power Protection type: Hiccup mode,recovers automatically after fault condition is removed			
	OVER VOLTAGE	7.0V MAX.		7.0V MAX.	
ENVIRONMENT	WORKING TEMP	-10 ~ +60°C (Refer to output load derating curve)			
	WORKING HUMIDITY	20% ~90% RH non-condensing			
	STORAGE TEMP,HUMIDITY	-20 ~ +85°C ; 10% ~95% RH			
	TEMP. COEFFICIENT	$\pm 0.03\% / ^\circ\text{C}$ (0 ~ 50°C)			
	VIBRATION	10~500Hz,2G 10min./1cycle,period for 60min. Each along X,Y,Z axes			
SAFETY & EMC <small>Note.4</small>	SAFETY STANDARDS	Meet UL1012,UL60950-1 ,TUV EN60950-1			
	WITHSTAND VOLTAGE	I/P-O/P:3KVAC I/P-FG:1.5KVAC O/P-FG:0.5KVAC			
	ISOLATION RESISTANCE	I/P-O/P,I/P-FG,O/P-FG:100M Ohms/500VDC			
	EMI CONDUCTION&RADIATION	Meet EN55022(CISPR22)Class B			
	HARMONIC CURRENT	Meet EN61000-3-2,-3			
	EMS IMMUNITY	Meet EN61000-4-2,3,4,5,6,8,11 ; ENV50204,EN55024,light industry level,criteria A			
OTHERS	MTBF	300K hrs min. MIL-HDBK-217F(25°C)			
	DIMENSION	129*98*38mm(L*W*H)			
	PACKING	TBD			
NOTE	<p>1.All parameters NOT specially mentioned are measured at 230VAC input,rated load and 25°C of ambient temperature.</p> <p>2.RIPPLE & NOISE are measured at 20MHZ of bandwidth by using a 12"twisted pair-wire terminated with a 0.1uf & 47uf parallel capacitor.</p> <p>3.Tolerance:includes set up tolerance,line regulation and load regulation.</p> <p>4.The power supply is considered a component which will be installed into a final equipment. The final equipment must be re-confirmed that it still meets EMC directives.</p>				



60W Dual Output Switching Power Supply

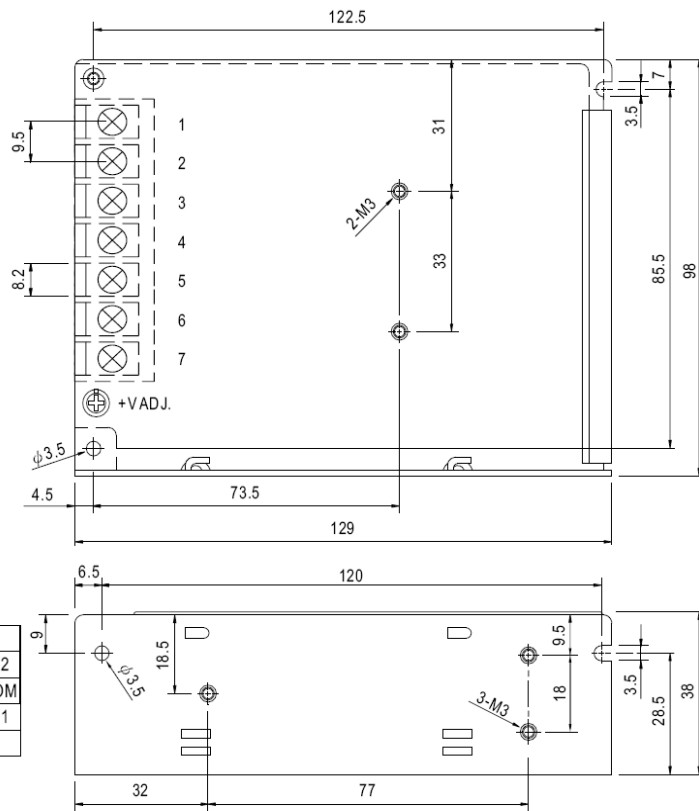

Terminal Pin. No Assignment

Pin No.	Assignment	Pin No.	Assignment
1	AC/L	5	DC OUTPUT +V2
2	AC/N	6	DC OUTPUT COM
3	FG \perp	7	DC OUTPUT +V1
4	DC OUTPUT COM		

Block Diagram

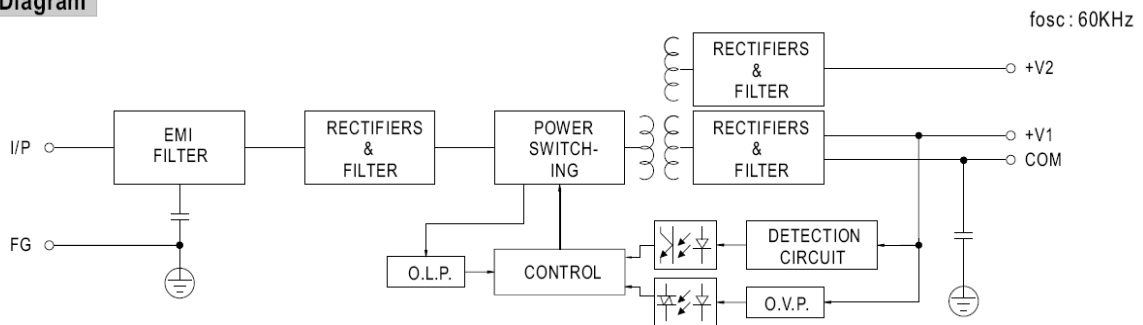

Derating Curve

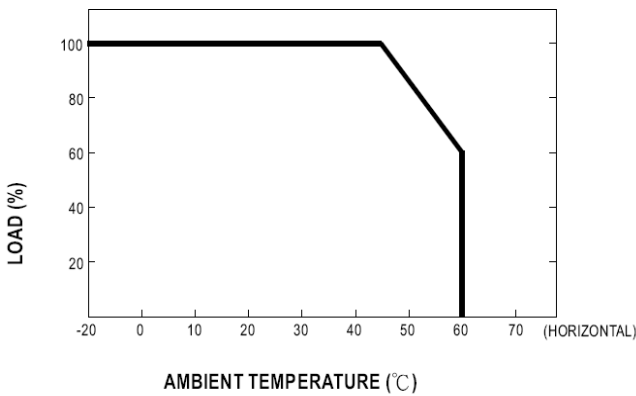

Output Derating VS Input Voltage

