

DIN CAST IRON NON-RISING STEM GATE VALVE, RESILIENT SEATED, F4 PN16

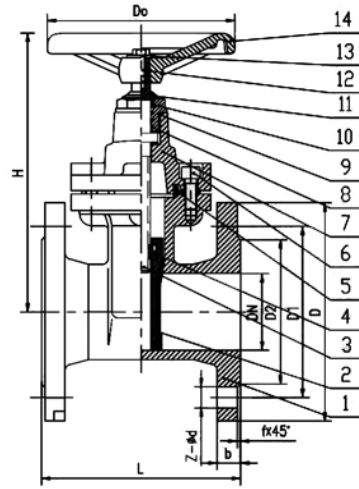

DESCRIPTION:

Available Medium: Water

Working Temperature: $\leq 50^{\circ}\text{C}$

Face to Face Dimensions: DIN3202 F4

Flange Dimensions: DIN2532

DIMENSIONS (MM)									
DN	L	D	D1	D2	b	Z-φd	f	H	KG
40	140	150	110	88	18	4-18	3	205	10.7
50	150	165	125	102	20	4-18	3	212	11.7
65	170	185	145	122	20	4-18	3	238	12.8
80	180	200	160	138	22	4-18	3	258	15.5
100	190	220	180	158	22	8-18	3	315	22.2
125	200	250	210	188	24	8-18	3	398	34.5
150	210	285	240	212	24	8-23	3	426	41
200	230	340	295	268	26	8-23	3	498	63.4
250	250	395	350	320	28	12-23	3	598	105.2
300	270	445	400	370	28	12-23	4	660	156.4

MATERIALS		
ITEM	PARTS NAME	MATERIAL
1	BODY	DUCTILE IRON
2	WEDGE DISC	DUCTILE IRON+RUBBER
3	STEM	STAINLESS STEEL
4	STEM NUT	BRASS
5	GASKET	RUBBER
6	HEXAGON SOCKET SCREWS	CARBON STEEL
7	BONNET	DUCTILE IRON
8	"O"RING	RUBBER
9	"O"RING	RUBBER
10	NUT	BRASS
11	SHIELD	RUBBER
12	BOLT	CARBON STEEL
13	GASKET	CARBON STEEL
14	WHEEL	DUCTILE IRON