

## DIN CAST IRON NON-RISING STEM GATE VALVE, METAL SEATED F4 PN16

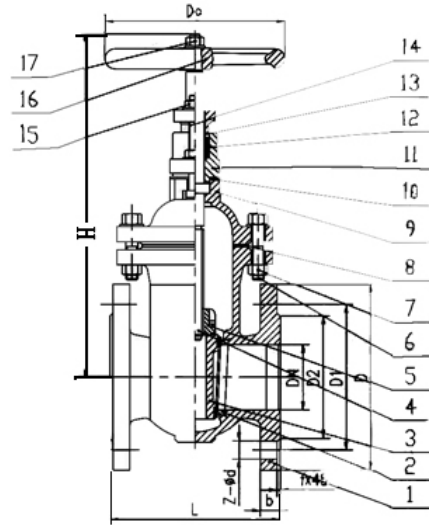

MATERIALS		
ITEM	PARTS NAME	MATERIAL
1	BODY	CAST IRON
2	SEAT	BRASS
3	WEDGE DISC	CAST IRON+BRASS
4	STEM	STAINLESS STEEL
5	STEM NUT	BRASS
6	BOLT	CARBON STEEL
7	NUT	CARBON STEEL
8	GASKET	GRAPHITE
9	BONNET	CAST IRON
10	GASKET	GRAPHITE
11	SUFFING BOX	CAST IRON
12	PACKING	GRAPHITE
13	GLAND	CAST IRON
14	BOLT	CARBON STEEL
15	NUT GASKET	CARBON STEEL
16	WHEEL	CAST IRON
17	NUT GASKET	CARBON STEEL

### DESCRIPTION:

Available Medium: T-Water, Steam W-Petroleum Products

Working Temperature: T ≤ 200°C, W ≤ 100°C

Face to Face Dimensions: DIN3202 F4

Flange Dimensions: DIN2501

DIMENSIONS (MM)										
DN	L	D	D1	D2	b	Z-φ d	f	D0	H	KG
40	140	150	110	88	18	4-18	3	160	278	15
50	150	165	125	102	20	4-18	3	160	331	18.36
65	170	185	145	122	20	4-18	3	160	342	22.78
80	180	200	160	138	22	8-18	3	180	363	29
100	190	220	180	158	22	8-18	3	200	382	35.3
125	200	250	210	188	24	8-18	3	280	457	54
150	210	285	240	212	24	8-23	3	280	492	69.1
200	230	340	295	268	26	12-23	3	280	586	101.8
250	250	395	350	320	28	12-27	3	320	676	141
300	270	445	400	370	28	12-27	4	320	737	208