

## DIN CAST IRON RISING STEM GATE VALVE, METAL SEATED, F4 PN16

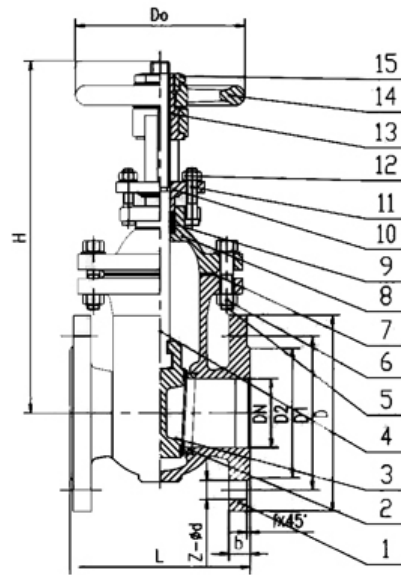

### DESCRIPTION:

Available Medium: Water

Working Temperature:  $\cong 150^{\circ}\text{C}$

Face to Face Dimensions: DIN3202 F4

Flange Dimensions: DIN2501

DIMENSIONS (MM)										
DN	L	D	D1	D2	b	Z- $\phi$ d	f	D0	H	KG
40	140	150	110	88	18	4-18	3	180	275	13.4
50	150	165	125	102	20	4-18	3	180	308	17.3
65	170	185	145	122	20	4-18	3	180	338	23
80	180	200	160	138	22	8-18	3	240	390	29.2
100	190	220	180	158	22	8-18	3	240	440	36.3
125	200	250	210	188	24	8-18	3	280	525	53.6
150	210	285	240	212	24	8-23	3	280	587	69.4
200	230	340	295	268	26	12-23	3	320	760	104.2
250	250	405	355	320	28	12-27	3	320	866	147
300	270	460	410	378	28	12-27	4	400	960	188.8

MATERIALS		
ITEM	PARTS NAME	MATERIAL
1	BODY	CAST IRON
2	SEAT	BRASS
3	WEDGE DISC	CAST IRON+BRASS
4	STEM	STAINLESS STEEL
5	BOLT	CARBON STEEL
6	NUT	CARBON STEEL
7	GASKET	GRAPHITE
8	BONNET	CAST IRON
9	PACKING	GRAPHITE
10	GLAND	CAST IRON
11	BOLT	CARBON STEEL
12	NUT GASKET	CARBON STEEL
13	STEM NUT	BRASS
14	WHEEL	CAST IRON
15	LOCKING NUT	CAST IRON