

## U-TYPE STRAINER

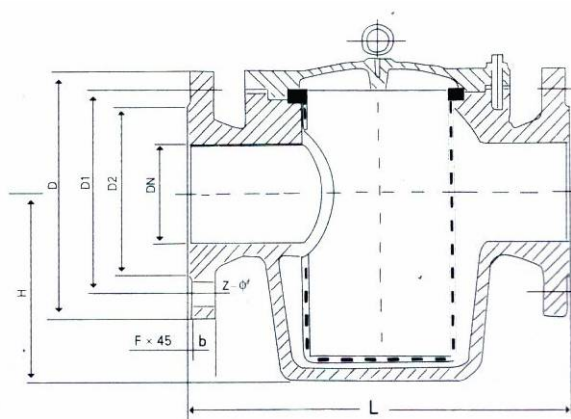

### DESCRIPTION:

Available Medium: Water, Petroleum

Working Temperature:  $\leq 120^{\circ}\text{C}$

Flange: DIN2532

Face to Face: DIN3202 F1

MATERIALS		
ITEM	PARTS NAME	MATERIAL
1	BODY/BONNET	GRAY CAST IRON
2	SCREEN	STAINLESS STEEL
3	BOLT/RING	CARBON STEEL
4	GASKET	GRAPHITE

DIMENSIONS (MM)								
DN	L	D	D1	D2	f	Z- $\phi$ d	H	kg
25	160	115	85	68	3	4-14	82	6.05
32	180	140	100	78	3	4-18	90	8.10
40	200	150	110	88	3	4-18	100	10.2
50	230	165	125	102	3	4-18	125	13.32
65	290	185	145	122	3	4-18	135	18
80	310	200	160	138	3	4-18	150	23.2
100	350	220	180	158	3	8-18	170	26.5
125	400	250	210	188	3	8-18	220	38.8
150	480	285	240	212	3	8-18	250	50
200	600	340	295	268	3	8-18	310	76.3