

GM-701, u-blox7

Ultra-High Performance

GNSS Smart Antenna Module

Overview

GM-701 is an easy to use, ultra-high performance, low power GPS smart antenna module with patch antenna for AVL/handheld applications. The built-in u-blox7 chip and our experienced design provide fast acquisitions and excellent tracking performance.

GM-701 supports either GPS/QZSS or GLONASS option. In addition, it also supports RS232/TTL/USB options; the built-in battery could also be omitted if external backup power is preferred.

Applications

- Tracking
- Navigation
- Driving recorder
- Fleet management
- Automatic vehicle location
- GPS clock and digital camera
- Child/elderly/personal locator and security system

Features

- Based on u-blox7 low power single chip
- High performance: -162dBm⁺ tracking sensitivity
- Low power: 37mA at continuous tracking (TTL, 9 SVs) / 43mA at continuous tracking (RS232, 9 SVs)
- SBAS (WAAS, EGNOS, MSAS) support
- GPS/QZSS(default) / GLONASS support
- A-GPS support, OMA SUPL/3GPP TS25.171 (GSM/UMTS) compliant
- RTCM 2.3 support

RoHS
Compliant

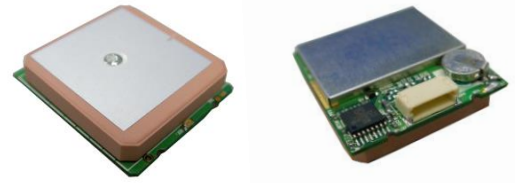

- Easy to use: built-in antenna & digital connector
- Built-in 25x25x4 (mm) patch antenna [Option of 25x25x2 (mm) patch available]
- Backup battery support for faster position fix
- External backup power option via I/O pin is available for special application of high working temperature.
- LED for position fix indication
- Windows **location sensor** support
- Linux/Android support
- Fully EMI shielded
- Industrial operating temperature range: -40 ~ 85°C

Technical Specifications

Receiver Performance Data⁺

Receiver Type	56-channel, u-blox 7 engine GPS & QZSS:L1 C/A,1575.42MHz, GLONASS:L1OF,1598.0625~1605.375MHz SBAS: WAAS, EGNOS, MSAS
Horizontal Position Accuracy	Autonomous:2.5m (GPS), 4m (GLONASS) SBAS: 2.0m (GPS) (CEP, 50%, 24-hour static, -130dBm)
Velocity Accuracy	<0.1 m/s (speed) <0.5° (heading) (50% @30m/s)
Time Pulse Signal Accuracy	RMS: 30ns (GPS), 50ns (GLONASS) 99%: 60ns (GPS), 100ns (GLONASS)
Time To First Fix	Autonomous (All at -130dBm) (50% -130dBm) Hot start
	1sec (GPS), 1sec (GLONASS)

Navisys Technology Corp.

Tel : +886-3-5632598

Sales contact: sales@navisys.com.tw

Address: 2F, No.56, Park Ave. II, Science-Based Industrial Park, Hsinchu 300, Taiwan (R.O.C.)

<http://www.navisys.com.tw/>

Fax: +886-3-5632597

Technical support: service@navisys.com.tw

Warm start	28sec (GPS), 25sec (GLONASS)
Cold start	29sec (GPS), 30sec (GLONASS)
Sensitivity (Autonomous)	Acquisition: -148 (GPS), -140 (GLONASS) Tracking: -162 (GPS), -158 (GLONASS)
Update Rate	Default: 1Hz, Max. : 10Hz
Max. Altitude	50,000 m
Max. Velocity	< 500m/sec
Protocol Support	NMEA 0183 v2.3(compatible to 3.0) UART: 9600 bps N,8,1; GGA, GLL, GSA, GSV, RMC, VTG, TXT
SBAS Support	WAAS, EGNOS, MSAS
Dynamics	<4g

*: according to GNSS IC spec

Electrical Data

Power Supply	3.3 ~ 5.5 V
Power Consumption; 9SVs	37mA/average tracking (TTL) 43mA/average tracking (RS232)
Backup power	3.3 V
TTL I/O	V _{IH} : 2.31~3.8V, V _{IL} : 0~0.66V V _{OH} : >=2.9V, V _{OL} < 0.4V
USB I/O	V _{IH} : 2.0~3.3V, V _{IL} : 0~0.8V V _{OH} : >2.8V, V _{OL} < 0.3V
Protocols	NMEA, u-blox Binary

Environmental Data

Operating temperature	-40 ~ 85°C except battery: -20~60°C
Storage temperature	-40 ~ 85°C except battery: -40~60°C
Vibration	5Hz to 500Hz, 5g
Shock	Half sine 30g/11ms

Mechanical Data

26*28*7.9 mm

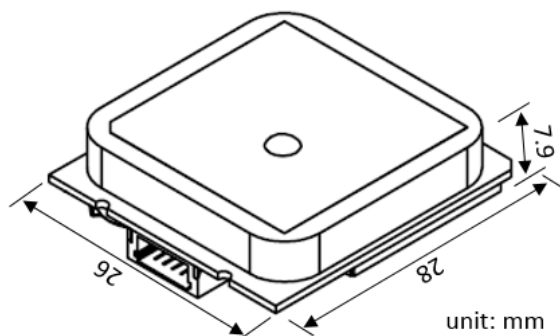

6-pin Interface, pitch 1.0mm

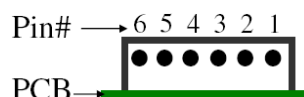

Pin	Name	Function	I/O
1	GND	Ground	Input
2	VCC	Power supply	Input
3	[§] TX/D+	Serial data output or USB D+	Output
4	[§] RX/D-	Serial data input or USB D-	Input
5	[§] TIMEPULSE (VBAT, option)	TIMEPULSE signal (External backup power)	Output (Input)
6	PWR_CTRL	Power control, high/floating: ON, low: OFF	Input

§: Signal level is RS232 only for RS232 version.

Ordering Information, GM-701X

Built-in backup battery

Where X=	R	T	U
RS232	Y	-	-
TTL	-	Y	-
USB	-	-	Y

Optional VBAT pin to support external backup power:

Where X=	Q	S	V
RS232	Y	-	-
TTL	-	Y	-
USB	-	-	Y

* Models other than R/T/U require MOQ.

* Option of thinner (2mm) is available.

*This document is subject to change without notice.