

MODEL: EA13070 SERIES

Size : $\varnothing 132.6 \times 72.5$
Unit : mm

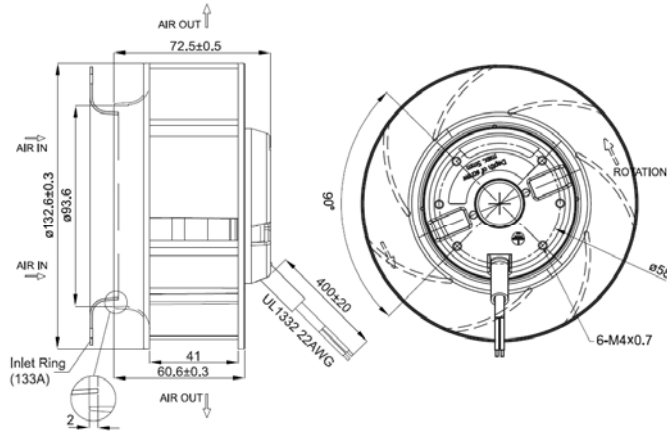

Thermal Protection



Lead Wire Type

(Centrifugal Fan)

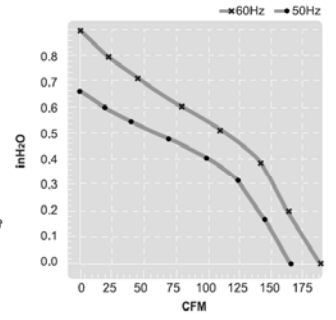

Model Spec	Rated Voltage V	Frequency Hz	Input Power W	Rated Current A	Locked Current A	Speed RPM	Maximum Air Flow m ³ /min	Maximum Air Flow CFM	Maximum Pressure mmH ₂ O	Maximum Pressure InchH ₂ O	Capacitor μ F/VDB	Noise dB	Weight KG
EA13070APA-11HS12A	115	50	38	0.50	0.83	2,780	4.66	165	16.6	0.65	—	50	0.9
		60	37	0.43	0.72	3,200	5.33	188	22.4	0.88		60	
EA13070APA-23H1S2A	230	50	36	0.24	0.39	2,780	4.66	165	16.6	0.65	—	50	0.9
		60	35	0.21	0.34	3,200	5.33	188	22.4	0.88		60	

We reserve the right to change data without notice.

MODEL: EA13090 SERIES

Size : $\varnothing 132.6 \times 91.5$
Unit : mm



Thermal Protection

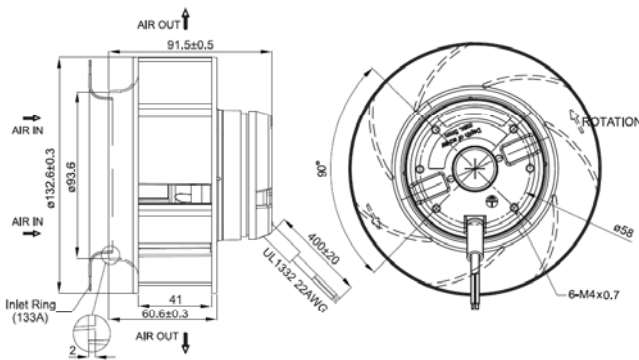

Lead Wire Type

(Centrifugal Fan)

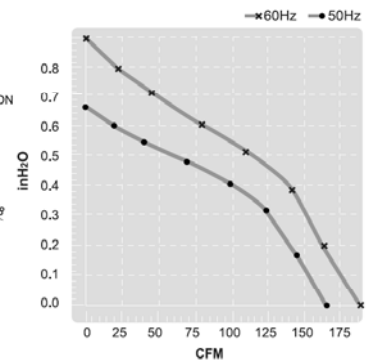

Model Spec	Rated Voltage V	Frequency Hz	Input Power W	Rated Current A	Locked Current A	Speed RPM	Maximum Air Flow m ³ /min	Maximum Air Flow CFM	Maximum Pressure mmH ₂ O	Maximum Pressure InchH ₂ O	Capacitor μ F/VDB	Noise dB	Weight KG
EA13090APA-11H1S2A	115	50	38	0.50	0.83	2,780	4.66	165	16.6	0.65	-	50	0.9
		60	37	0.43	0.72	3,200	5.33	188	22.4	0.88		60	
EA13090APA-23H1S2A	230	50	36	0.24	0.39	2,780	4.66	165	16.6	0.65	-	50	0.9
		60	35	0.21	0.34	3,200	5.33	188	22.4	0.88		60	

We reserve the right to change data without notice.