

UNIPOWER

GEL120-12(12V120Ah)

PHYSICAL SPECIFICATION

Nominal Voltage Nominal Capacity (10HR)		12V 120Ah	
Dimension	Length	406±2mm (15.98 inches)	
	Width	174±2mm (6.85 inches)	
	Container Height Total Height	207±2mm (8.15 inches) 232±2mm (9.13 inches)	
Weight		Approx. 37Kg (81.5lbs)	
Standard Terminal		Bolt-and-nut lead terminal Bolt Type: M6	

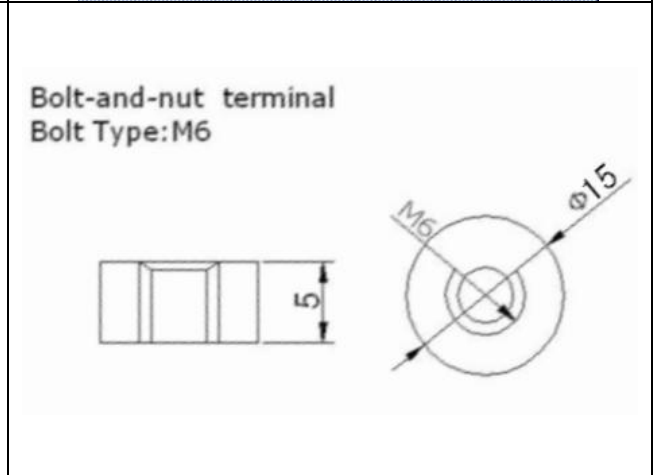
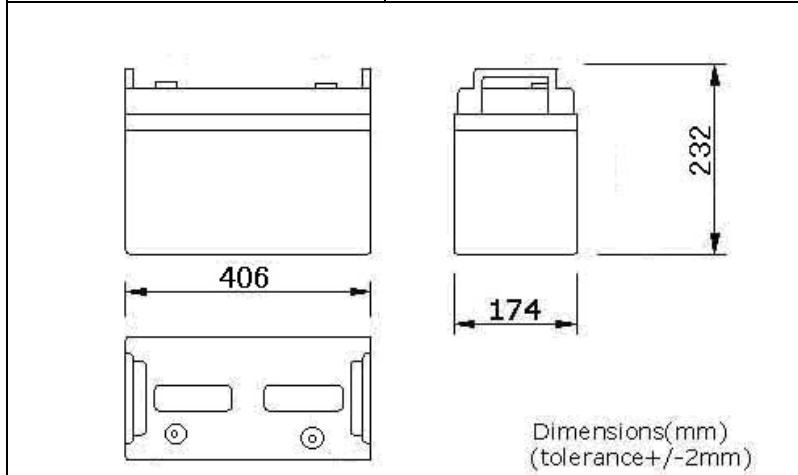

ELECTRICAL SPECIFICATION

Characteristics			Discharge curves @ 25°C (77 ° F)
Capacity	10 hour rate (12A) 5 hour rate (20.4A) 3 hour rate (30A) 1hour rate (72A)	120Ah 102Ah 90Ah 72Ah	<p>Discharge Characteristics(25°C/77 ° F)</p>
Capacity affected by temperature	40°C (104 °F) 25°C (77 °F) 0°C (32 °F)	102% 100% 85%	
Designed life	≥720 Cycles 50% DOD (25°C)		
Internal Resistance	Full charged battery (25°C,77 °F)4.7mΩ		
Constant Voltage Charge	Cycle	Initial Charging Current less than 30A Voltage 14.1~14.4V at 25°C (77 °F) Temperature Coefficient -5mV/°C	
	Standby	No limit on Initial Charging Current Voltage 13.5~13.8V at 25°C (77 °F) Temperature Coefficient -3.3mV/°C	