

SPECIFICATION

1. DESCRIPTION

The DK1203 is a secondary side flyback type AC-DC Switch Mode Power Controlling IC. With integrated 700V high voltage power transistor, patented self-power supply circuit and integrated CMOS circuit design, lots of external components are saved, transformer design is simple, only two windings are needed for the transformer in isolated output circuit.

2. APPLICATIONS

- AC/DC power adapters
- Air conditioner power supply
- DVB power supply
- TV/Monitor power supply
- DVD/VCD power supply
- Electromagnetic oven power supply
- LED driver applications

3. MAIN FEATURES

- 85V—264V wide range AC power input
- Internal integrated 700V high voltage power transistor
- Internal integrated constant high voltage current driving circuit, no need for additional resistance.
- Self-power supply circuit design, no need for additional electricity supply to IC, so that could reduce component and cost
- 65KHz PWM switching frequency
- Standby power: <0.3W
- Built in frequency jittering function to reduce standby frequency and output voltage ripple
- Internal Ramp Compensation circuit to keep the stability of the circuit
- Internal PMW oscillation circuit with Frequency jittering control to low down EMI filtering cost
- Over current, Over temperature, Over voltage, Output short circuit and Secondary side open circuit Protection.
- 4KV Anti-Static ESD test.

4. POWER RANGE

Model NO.	Input Voltage	Rated Output Power
DK1203	85-264V AC	12W
DK1203 高档	85-264V AC	15W

Remark: Test at 45 °C in an enclosed environment

5. CONNECTION DIAGRAM (DIP-8)

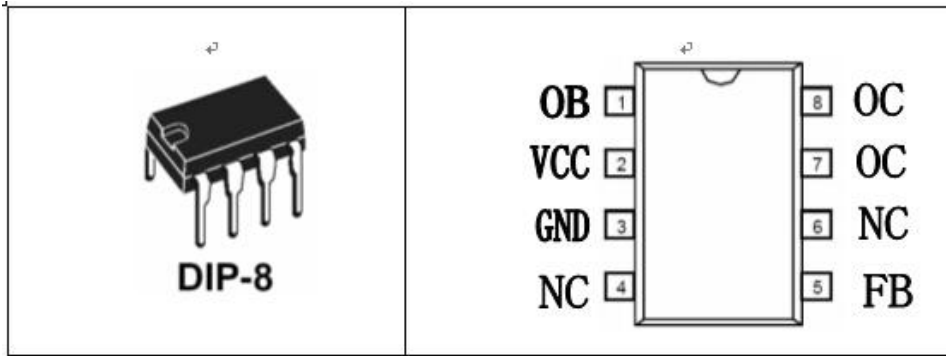

PIN FUNCTION

Pin NO.	Pin Name	Function
1	OB	Startup pin. Internal startup circuit to contact with OC pin.
2	VCC	Power supply of control circuits, contacted with an external grounded capacitor of 10uF~47uF
3	GND	Ground reference
4	NC	Empty pin without internal connection.
5	FB	Feedback control pin, connected with 1nF~10nF grounded capacitor
6	NC	Empty pin without internal connection.
7,8	OC	Output pin. Connected with internal high voltage Collector point and switch mode transformer.

6. BLOCK DIAGRAM

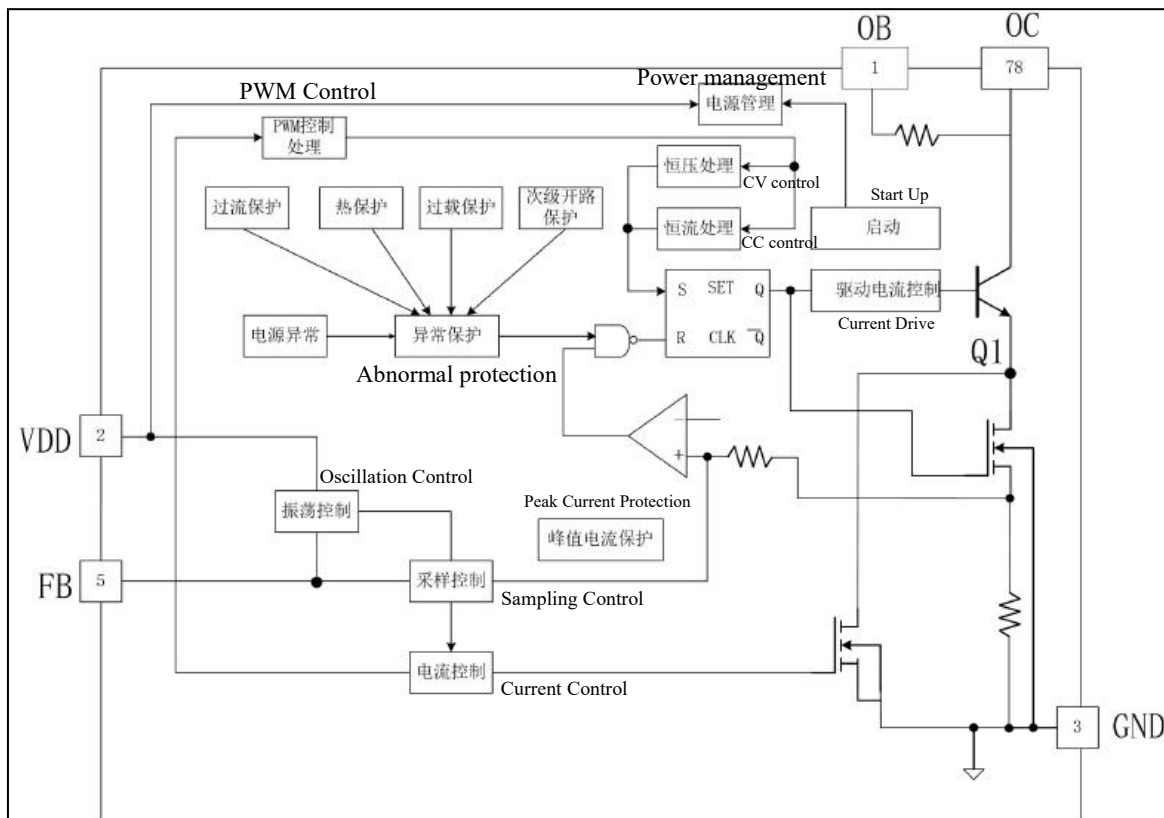

7. ABSOLUTE MAXIMUM RATINGS

Parameter	Symbol	Min	Typ	Max	Unit
Supply Voltage VCC	U_S	-0.3		8V	V
Supply Current VCC	I_S		100		mA
Pin Voltage	U_{PV}	-0.3		VDD+0.3	V
Breakdown Voltage	U_{PP}			730	V
Peak Current	I_{PEAK}			800	mA
Total Dissipation Power	P_{TOT}		1000		mW
Working Temperature Range	T_R	-25		125	°C
Storage Temperature Range	T_{STG}	-55		150	°C
Soldering Temperature	T_W		280/5S		°C

8. ELECTRICAL CHARACTERISTIC ($T_A = 25^\circ\text{C}$)

Parameter	Testing Condition	Min.	Typ.	Max.	Unit
VCC (Working voltage)	AC input: 85V-265V		4.7		V
VCC Start up Voltage	AC input: 85V-265V		4.9		V
VCC restart Voltage	AC input: 85V-265V		3.4		V
VCC protect Voltage	AC input: 85V-265V		5.8		V
Current of VCC	VCC=4.7V, Fb=2.2V	10	20	30	mA
High voltage start up current	AC input: 265V			1.2	mA
Start up time	AC input: 85V, C=100uF	--	--	500	mS
OC Protection Voltage	L=1.2mH		610		V
BJT Breakdown voltage	Ioc=1mA	700	--	--	V
Power transistor Current	VCC=4.7V, Fb=1.3V---3.0V	600	660	700	mA
Peak Current Protection	VCC=4.7V, Fb=1.3V---3.0V	650	720	800	mA
PWM output Frequency	VCC=4.7V, Fb=1.6V---3.0V	50	65	70	KHz
PWM output Frequency	VCC=4.7V, Fb=1.3V---1.6V		20		KHz
Temperature protection	VCC=5V, Fb=1.6V---3.6V	120	125	130	°C
LEB time	VCC=4.7V		250		ns
Min. turn-on time	VCC=4.7V		500		ns
Duty cycle of PWM	VCC=4.7V, Fb=1.6V---3.6V	5		75	%
Standby power				270	mW

9. OPERATION PRINCIPLE

9.1 Start Up

With its internal high voltage constant current driving circuit, after power on, if VDD voltage is lower than start up voltage, the external VDD capacitor would be charged, when the voltage of VDD reaches 4.9V, starting up process finished and PWM pulse is output.

9.2 Soft Start

4ms soft start circuit is integrated. Within 4ms after starting up, peak current of primary side is 330mA, clock frequency is 65K. After that, peak current of primary side is 660mA, clock frequency is 65K.

9.3 PWM output

One PWM cycle includes 3 phases:

First is inductor charging (transistor turn on), $T1=Lp*Ip/Vin$;

Second is inductor discharging (transistor turn off), $T2=Lp*Ip/Vor$;

Third is OC resonance stage, $T=2\pi(Lp*Coc)^{1/2}$

IC is of fixed 65K frequency output mode, turn on time is controlled by FB feedback voltage.

9.4 FB detecting and feedback control

Fb pin should be connected with an external capacitor, as to smooth the FB voltage. Typical use should choose value of 1nF~10nF.

When Fb voltage more than 3.6V MAX. Ip is 660mA.

While Fb voltage is dropping from 3.6V to 2.8V, Ip decreases accordingly, $Ip=T1*Vin/Lp$, $T1min=500ns$.

While Fb voltage between 3.6V and 2.8V, working frequency is fix at 65KHz.

While Fb voltage is dropping from 2.8V to 1.6V, working frequency decreases accordingly.

When Fb voltage < 1.6V, PWM output stops.

9.5 Self-Power Supply Circuit (National patent owned)

There is self-power supply circuit inside the IC, which can control the power voltage at about 4.7V for the electricity consumption of the IC itself. It can only afford the electricity consumption of itself but not the external circuit.

9.6 Over Temperature Protection (OTP)

When the controller detects the device temperature exceeds 125°C, OTP is activated. It stops the switching operation immediately and enters into the stop status. The controller will restart to switching operation when the temperature falls down.

9.7 Primary side short circuit protection

If current on primary side wiring of transformer reach as high as 660mA, (after soft start, at the time of 500ns after PWM turn on, this current is detected), transistor is cut off and IC enters into abnormal protection status.

9.8 Abnormal Voltage Protection

Whenever the power voltage (Vcc) abnormally exceeds 5.8V or drops under 3.4V, the controller would stop operation and enters into stop status.

9.9 Short Circuit/Over Load Protection

If secondary side short circuit or over load, Fb voltage would go up to more than 3V. As in some application, higher current is needed to start up and cause short time over load, so if this situation can recover within 500ms, IC would work normally. But if the over load situation lasts more than 500ms, and the Fb voltage is higher than 3V continuously, transistor would be cut off and IC enters into abnormal protection status.

At the same time, the detecting time reduces to 32ms until the situation recovers.

9.10 Secondary side open circuit Protection

Whenever OC voltage is more than 610V, transistor would be cut off and IC enters into abnormal protection status until it drops down to lower than 610V.

9.11 Abnormal Protection mode

When IC enters into abnormally protection mode (stop=1), transistor would be cut off and 500ms timer activated. Within 500ms, if VOC drops and keeps at 4.6V, IC will return to normal after that.

10. TYPICAL APPLICATION

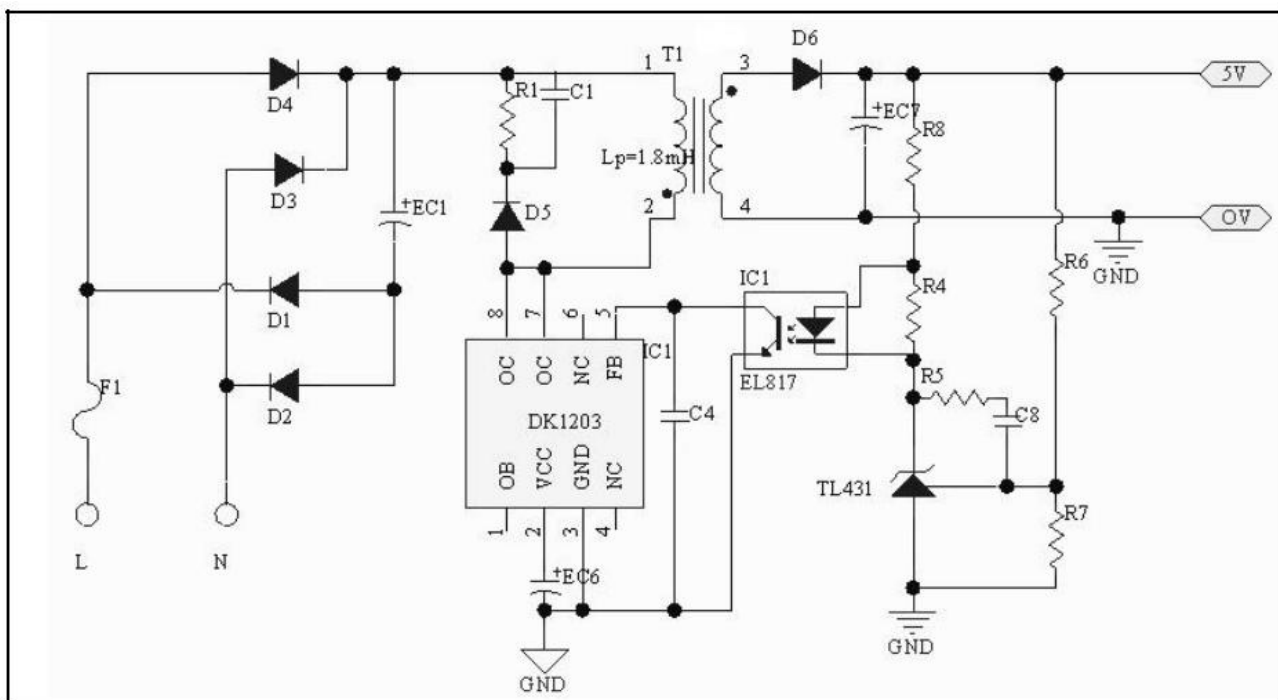

11. SPECIAL NOTICE FOR PBC LAYOUT DESIGN

11.1 Heat dissipation: A good estimate is that the controller will dissipate the output power. So enough cooper area connected to the 7, 8 COLLECTED pins and tin-plating are necessary to provide the controller heat sink.

11.2 The 7, 8 COLLECTED pins is high voltage part of the IC, peak voltage is as high as 600V, so it should be at least 1.5mm far away from the low voltage part in the PCB as to avoid circuit breakdown and discharging.

12. MECHANICAL AND PACKING INFORMATION

Symbol	Dimensions In Millimeters		Dimensions In Inches	
	Min	Max	Min	Max
A	3.710	4.310	0.146	0.170
A1	0.510		0.020	
A2	3.200	3.600	0.126	0.142
B	0.380	0.570	0.015	0.022
B1	1.524 (BSC)		0.060 (BSC)	
C	0.204	0.360	0.008	0.014
D	9.000	9.400	0.354	0.370
E	6.200	6.600	0.244	0.260
E1	7.320	7.920	0.288	0.312
e	2.540 (BSC)		0.100 (BSC)	
L	3.000	3.600	0.118	0.142
E2	8.400	9.000	0.331	0.354

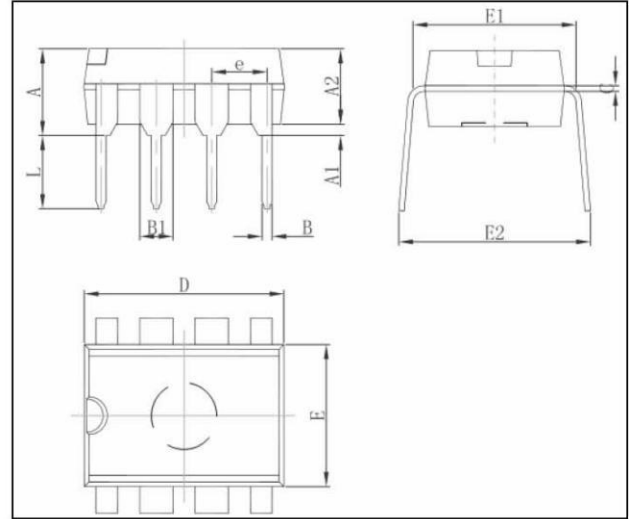

· Antistatic pipe packing:

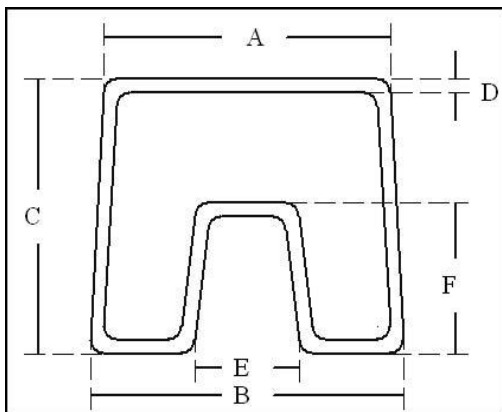

signal	MIN. (mm)	RATED (mm)	MAX. (mm)
A	11	11.5	12
B	11.5	12	12.5
C	10	10.5	11
D	0.4	0.5	0.6
E	3.5	4	4.5
F	5	5.5	6

· Packing quantity

QTY/tube	QTY/inner carton	QTY/master carton
50	2000	20000