

Power Splitter/Combiner

1411-B471

2020-03-20 Rev. 0



75Ω 2 Way-0° Power Divider 5-1250 MHz

Outline Drawing(mm)

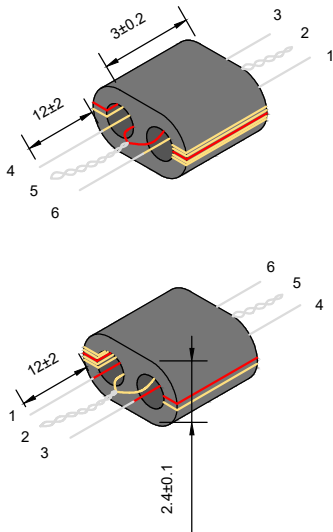

Electrical structure

Fig K

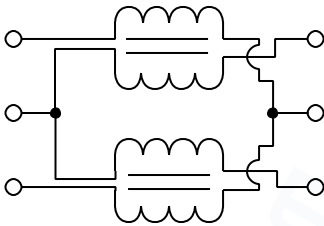

Application circuit

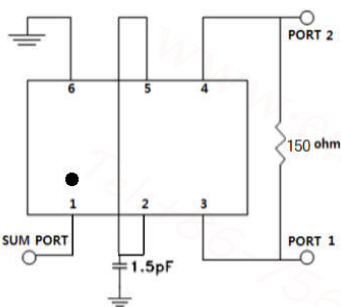

Pin Connections

SUM PORT	1
PORT 1	3
PORT 2	4
GROUND	6
External 1.5 pF Capacitor	2,5

Features

- Operating temperature range: -40℃ to +85℃
- Storage temperature range: -55℃ to +100℃
- Low insertion loss
- 6 pins DIP and THT
- RoHS compliant

Applications

- For CATV broadband applications
- For VHF/UHF receivers/transmitters and push - pull amplifiers

Electrical Specifications:TA=25℃, 0dBm, Z0=75Ω

Parameter	Test Conditions	Units	Min	Typ	Max
Main line Loss (Pin1-3)	5-1250MHz	dB	—	1.0	2.0
Main line Loss (Pin1-4)	5-1250MHz	dB	—	1.2	2.5
Input Return Loss	5-1250MHz	dB	16.0	20.0	—
Output Return Loss 1	5-1250MHz	dB	12.0	16.0	—
Output Return Loss 2	5-1250MHz	dB	12.0	16.0	—
Isolation	5-1250MHz	dB	16.0	20.0	—

