



东汇电机

DONG HUI MOTOR

直流减速电机
DC gear motor

DGA12-20



减速比 REDUCTION RATION	L (mm)	减速比 REDUCTION RATION	L (mm)
1/10~1/422	9		
1/1000	12		

外形尺寸/Dimensions

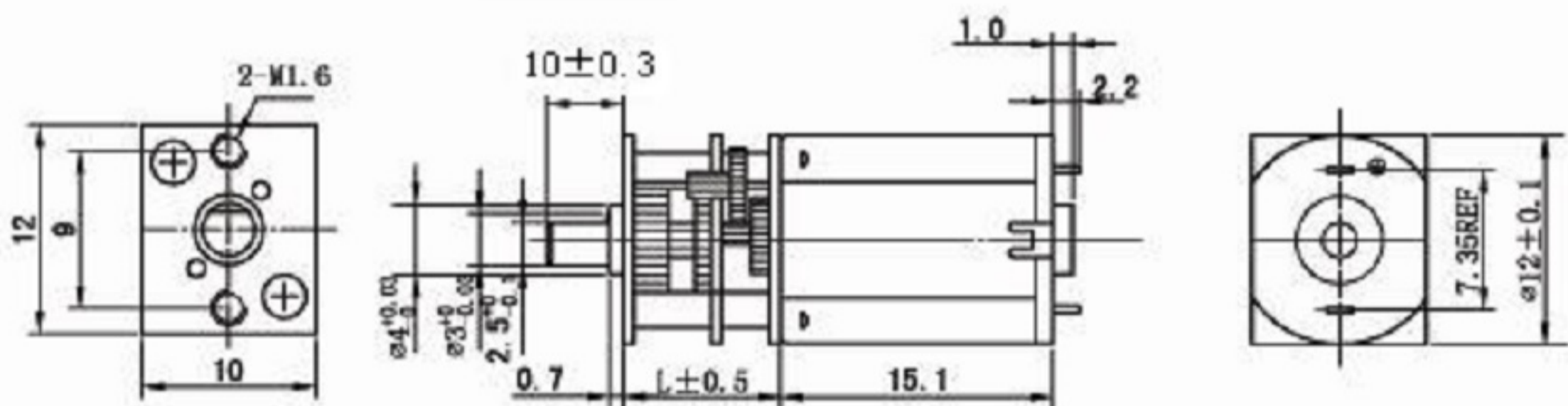

UNIT:MM

直流减速机参数/DC speed reducer parameters

电压 VOLTAGE	减速比 REDUCTION RATIO	1/10	1/20	1/30	1/50	1/100	1/150	1/210	1/250	1/298	1/340	1/380	1/422	1/1000			
2.5	额定扭力 (g-cm) RATED TORQUE	20	36	54	91	165	247	309	368	439	500	560	622	1250			
	额定转速 (rpm) RATED SPEED	1210	605	403	242	121	80	57	48	40	35	31	28	12			
	瞬间容许扭力 (g-cm) MAX MOMENTARY TOLERANCE TORQUE	105	189	284	474	858	1280	1610	1910	2285	2600	2900	3000	4000			
	空载转速 (rpm) NO LOAD CURRENT	1490	745	496	298	149	99	70	59	50	43	39	35	15			
6	额定扭力 (g-cm) RATED TORQUE	20	36	54	91	165	247	309	368	439	500	560	622	1250			
	额定转速 (rpm) RATED SPEED	1180	590	390	236	118	78	56	47	39	34	31	27	11			
	瞬间容许扭力 (g-cm) MAX MOMENTARY TOLERANCE TORQUE	97	175	262	438	792	1188	1486	1770	2109	2407	2690	2987	4000			
	空载转速 (rpm) NO LOAD CURRENT	1500	750	500	300	150	100	71	60	50	44	39	35	15			

电机参数/Motor data

型号 MODEL	额定电压 RATED VOLT V	空载 NO LOAD		最大效率 AT MAXIMUM EFFICIENCY					堵转	
		转速 SPEED r/min	电流 CURRENT A	转速 SPEED r/min	电流 CURRENT A	扭矩 TORQUE g-cm	输出功率 OUT PUT W	效率 EFF %	扭矩 TORQUE g-cm	电流 CURRENT A
DFF-N20NA-1	2.5	14900	0.06	12100	0.254	2.5	0.26	42	13	1.06
DFF-N20NA-2	6	15000	0.028	11700	0.120	2.5	0.29	41	11.9	0.37