

Ordering Information

HC-PGC	Type	Length A	NO.OFPIN	SR	Plating		
					Plunger	Barrel	Packing
C=Connector	SMT/平底= A	XXX	1P-12P	XX	针轴膜厚	针管膜厚	1= Bag
	Dip/ 插板= B				G1=3U"	G1=3U	T=Tube
	Solder /焊线=C				G2=5U"	G2=5U	R=Reel
	Double Header/双头=D				G3=10 U"	G3=10	A=Box
	Bending/折弯= E				G4=15 U"	G4=15	
	Other/其他= F				G5=20 U"	G5=20	
	Lathe/车削件= G				G6=25 U"	G6=25	
					G7=30 U"	G7=30	

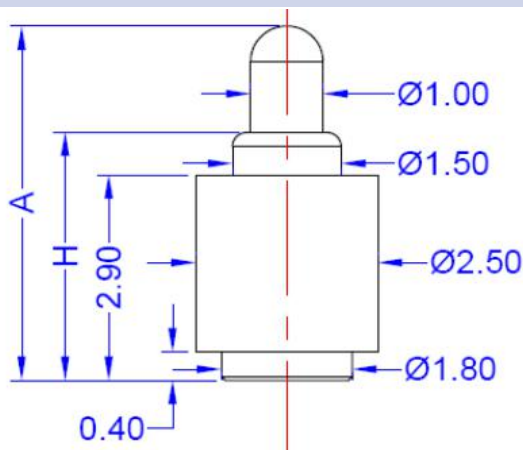

材质(Material)

针轴 (Plunger) : Brass 3604

针管 (Barrel) : Brass 3604

弹簧 (Spring) : SUS 304

环境性能(Environment Performance)

工作温度范围(Operating Temp): -40°C~ +105°C

焊锡耐热性(Resistance to Solder heat) :260°C±5°
20s±2s

盐雾测试(Salt spray) :48H

额定电压 (Votage) : 3-36V

额定电流 (Current) : 1-3A

PIN :1P T 12P

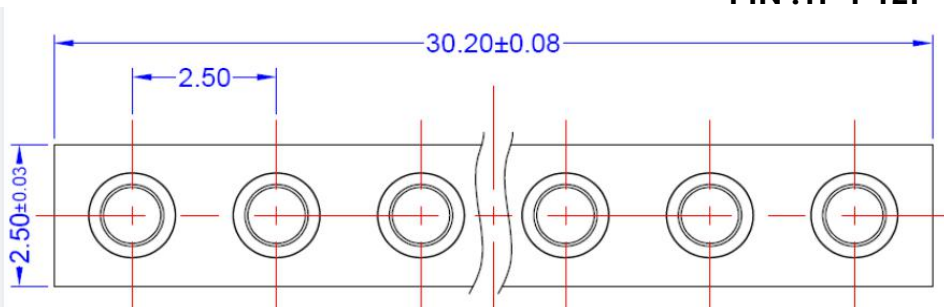

Series	P/N	Length A(mm)	H(mm)	Stroke (mm)	Full Stroke (mm)	Force (gF)	Resistance (mΩ)
1	HC-PGC-A2.5-026-XX-11-XX-XX-X	2.6	1.8	0.6	0.7	100±20	50
2	HC-PGC-A2.5-028-XX-12-XX-XX-X	2.8	1.8	0.6	0.7	100±20	50
3	HC-PGC-A2.5-030-XX-11-XX-XX-X	3.0	1.8	0.8	0.9	100±20	50
4	HC-PGC-A2.5-032-XX-11-XX-XX-X	3.2	2.4	0.8	0.9	100±20	50
5	HC-PGC-A2.5-034-XX-12-XX-XX-X	3.4	2.4	0.8	0.9	100±20	50
6	HC-PGC-A2.5-036-XX-11-XX-XX-X	3.6	2.7	0.8	1.0	100±20	50
7	HC-PGC-A2.5-038-XX-12-XX-XX-X	3.8	2.7	0.8	1.0	100±20	50
8	HC-PGC-A2.5-041-XX-13-XX-XX-X	4.1	2.7	0.8	1.0	100±20	50
9	HC-PGC-A2.5-043-XX-11-XX-XX-X	4.3	3.1	1.0	1.2	120±20	50
10	HC-PGC-A2.5-045-XX-12-XX-XX-X	4.5	3.1	1.0	1.2	120±20	50
11	HC-PGC-A2.5-050-XX-11-XX-XX-X	5.0	3.5	1.0	1.4	90±20	50
12	HC-PGC-A2.5-055-XX-11-XX-XX-X	5.5	4.5	1.0	1.4	70±20	30