

# SPECIFICATION

## 1. DESCRIPTION

The DK124 is a secondary side fly-back type AC-DC Switch Mode Power Controlling IC. Designed with high integration CMOS circuit, it has protection functions for short circuit, secondary side open circuit, over temperature, over voltage and so on. With built-in HV power transistor and patented Self-Power supply circuit, it has the characteristics of saving external components, simple transformer design with only two windings in isolated output circuit, etc.

## 2. APPLICATIONS

- Battery charger
- Power AC/DC adapters
- STB power supply
- Electromagnetic oven power supply
- DVD/VCD/VCR power supply
- Air conditioner power supply
- LED driver applications
- TV/Monitor power supply

## 3. MAIN FEATURES

- 90V—265V wide range AC power input.
- Built-in 700V HV BJT
- Internal integrated high voltage starting circuit, no need for additional resistance
- Burst mode (22kHz Intermittent operation mode)
- Standby power consumption < 0.3W
- 65KHz PWM switching frequency
- 4KV ESD
- Internal power compensation circuit to keep the stability of output in different input situation
- Patented self-power supply design, no need for auxiliary winding in transformer
- Internal frequency modulation circuit to reduce EMI filter cost
- Over current, Over temperature, Over voltage, Output open circuit and Short circuit Protection

## 4. POWER RANGE AND PRINTING

MODEL NO.	PRINTING ON IC	INPUT VOLTAGE	TYPICAL POWER
DK124	YYXXGZ DK124	90-265V AC	18W

### REMARK:

1. YY: code of year. XX: code of batch. G: code of version. Z: internal code
2. The typical power is tested in a closed environment at 45 °C

## 5. CONNECTION DIAGRAM (DIP-8)

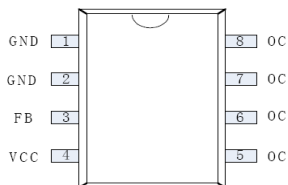
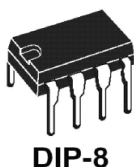

### PIN FUNCTION

Pin NO.	Pin Name	Function
1	GND	Ground reference of IC
2	GND	Ground reference of IC
3	FB	Feedback control pin, external grounded connecting with 1nF~4.7nF capacitor
4	VCC	IC Power supply pin, external grounded connecting with 47uF~100uF capacitor(LOW ESR type better, especially in low temp. working)
5,6,7,8	OC	Output pin of power transistor, externally connected with transformer

## 6. BLOCK DIAGRAM

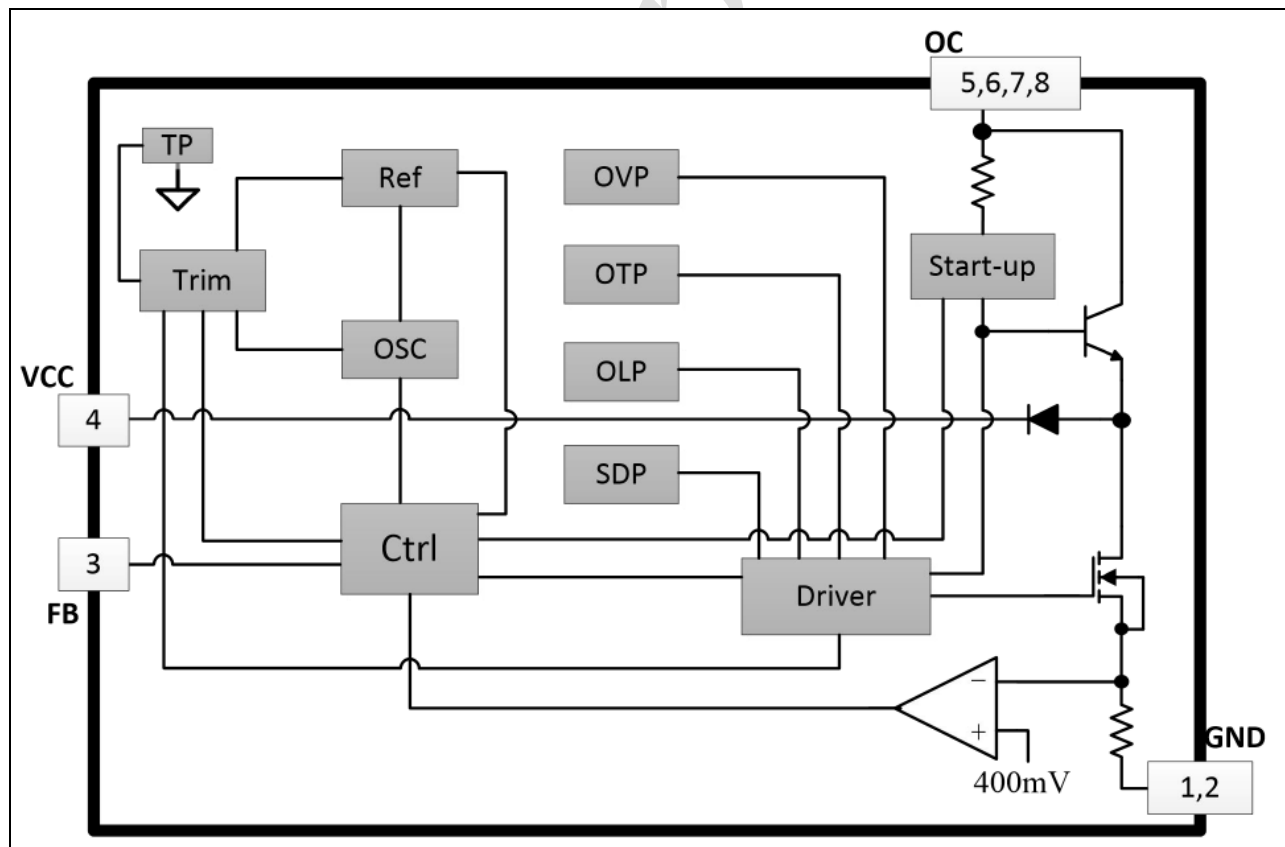

## 7. ABSOLUTE MAXIMUM RATINGS

Parameter	Symbol	MIN. Value	Rated Value	MAX. Value	Unit
Supply voltage	U <sub>S</sub>	-0.3		8	V
Current of supply voltage	I <sub>S</sub>		100		mA
Pin voltage	U <sub>PV</sub>	-0.3		VDD+0.3	V
Collector to GND voltage /Breakdown voltage	U <sub>PP</sub>	-0.3		700	V
Peak current	I <sub>PEAK</sub>			1300	mA
Dissipation power	P <sub>TOT</sub>		1000		mW
Case operating temperature	T <sub>R</sub>	-25		125	°C
Storage temperature	T <sub>STG</sub>	-55		155	°C
Lead soldering temperature	T <sub>W</sub>		285/5S		°C

## 8. ELECTRICAL CHARACTERISTIC

Parameter	Condition	Value			Unit
		Min.	Typ.	Max.	
VCC (Work Power Supply)	AC input: 85V-265V	4.9	5	5.9	V
Start threshold Voltage	AC input: 85V-265V		5.2		V
Restart Voltage	AC input: 85V-265V	3.3	3.6	3.9	V
Protect Voltage of VCC	AC input: 85V-265V		6.1		V
Working Current of VCC	VCC=5V, Fb=1.5V			50	mA
High voltage start current	AC input: 85V-265V	0.3	0.6	1.2	mA
Start time	AC input: 85V	--	--	500	mS
BJT Breakdown voltage	I <sub>oc</sub> =1mA	700	--	--	V
Peak Current Protection	VCC=5V, Fb=1.5V---2.8V		1250		mA
PWM Output frequency	VCC=5V, Fb=1.5V---2.5V	61	65	69	Khz
Burst mode frequency	VCC=5V, Fb=2.5V---2.8V	20	22	24	Khz
Stepped Frequency			0.5		Khz
Short circuit protection threshold	Tested FB voltage		0.8		V
frequency conversion threshold voltage	Tested FB voltage		2		V
Burst mode threshold	Tested FB voltage		4.2		V
Temperature protection	junction temperature	120	130	140	°C
Leading edge blanking time	VCC=5V, Fb=1.5V---2.5V		250		nS
Min. turn-on time	VCC=5V, Fb=2.6V		500		nS
Duty cycle of PWM	VCC=5V, Fb=1.5V---2.5V	5	--	70	%
Standby power consumption	AC input: 265V, unloaded			270	mW

Remark: (TA = 25°C if not specified)

## 9. OPERATION PRINCIPLE

### 9.1 Start Up

When power on, external VCC capacitor is charged by internal high voltage constant current coming for internal connected OC and VCC pins. When V<sub>CC</sub> voltage comes up to 5.2V, starting up finishes, the circuit enters into normal working mode and outputs PWM.

### 9.2 Soft-start

After power on, the IC starts to output PWM pulse. In order to prevent instantaneous output voltage overshoot and saturation of transformer core, which cause excessive stress of power transistor and secondary rectifier tube, the IC has built-in soft start circuit. In the first 128 PWM, and the primary peak current is  $1/2 \cdot I_{p\_max}$ , switching frequency is 22kHz. In the 128 ~ 256 PWM, primary peak current is  $I_{p\_max}$ . After the 256 PWM, the switching frequency increases to 66KHz

### 9.3 Feedback Control

The chip adopts the PWM control mode, which limits the peak current by cycles, and adjusts the limiting current by detecting the feedback voltage of FB. When PWM is turned on, the chip detects the output current of the power transistor, until the output current of the power transistor reaches the current limit current, the power transistor is turned off and waits for the next PWM turn-on cycle. When FB voltage is between 1.2v-2.1v, it will adjust the limiting current linearly. 1.2V corresponds to the maximum limiting current, and 2.1V corresponds to the intermediate section current control current. When the load continues to decrease, FB increases from 2.1V to 3V, the current is fixed as the middle section current, and the working frequency changes linearly from 66KHz to 22kHz. When the load continues to decrease, FB increases from 3V to 3.9v, the frequency is fixed at 22kHz, and the current decreases linearly from the middle section current to the minimum current. When the load increases, FB voltage will gradually decrease; otherwise, FB voltage will gradually increase. When the load is too heavy and FB voltage is less than 0.8V, the chip will enter the judgment of short circuit or overload protection.

### 9.4 Burst mode (Intermittent operation mode)

When there is no load or light load, FB voltage will rise to v<sub>dd</sub>-0.8v and the chip will stop PWM output. When the output voltage drops slightly and FB voltage is lower than v<sub>dd</sub>-0.8v, the chip will re output some PWM pulses to maintain the set output voltage. This intermittent output mode can effectively reduce the switching frequency to improve the light load efficiency.

### 9.5 Self-Power Supply Circuit (National patent owned)

There is self-power supply circuit inside the IC, which can control the VCC voltage at about 5V for the electricity consumption of the IC itself. It can only afford the electricity consumption of itself only but can't afford for the external circuit.

### 9.6 Frequency Jittering Circuit

In order to meet the design requirements of EMI and reduce the design complexity and cost of EMI, a frequency modulation circuit is set in the chip. Under medium and heavy load, the PWM frequency will be 65kHz as the center and 0.5KHz step frequency will run on 16 frequency points. Under light load, the frequency will be reduced to 22 kHz. When the load is smaller, PWM action will be interrupted or stopped.

### 9.7 Over Temperature Protection (OTP)

When the controller detects the device temperature exceeds 130°C, OTP is activated. It stops the switching operation immediately and enters into the stop status. The controller will restart to switching operation when the temperature falls down.

### 9.8 Over Current Protection (OCP)

Whenever the collector current (Ip) abnormally exceeds the maximum current limit of 1.3A, the controller would stop operation and enters into stop status.

### 9.9 Abnormal Voltage Protection

Whenever the power voltage (Vcc) abnormally exceeds 6.1V and drops under 3.6V, the controller would stop operation and enters into stop status until the voltage comes back to normal.

### 9.10 Over Reflected Voltage Protection

When an abnormal open circuit occurs in the secondary circuit, the input bus voltage will rise, resulting in a high peak voltage at the OC pin of the power transistor. In order to protect the power transistor, when the reflected voltage inside the chip exceeds the protection threshold voltage  $VOR_{OVP}$ , the chip triggers the reflected voltage overvoltage protection. The protection threshold voltage can be set by the following formula:

$$VOR_{OVP} = Lp * Ip/6$$

The units are uH, A and US respectively. LP is the primary inductance and IP is fixed at 1.25A

### 9.11 Constant Power Control

To avoid too high power output in high input voltage, there is internal power compensation circuit to keep the stability of output in both low voltage and high voltage input.

### 9.12 Short Circuit and Over Load Protection

If secondary side short circuit or over load, Fb voltage would drop down to lower than 0.8V. As in some application, higher current is needed to start up and cause short time over load, so if this situation can recover within 512ms, IC would work normally. But if the over load situation lasts more than 512ms, and the Fb voltage is lower than 0.8V continuously, transistor would be cut off and IC enters into abnormal protection status.

## 10. SPECIAL NOTICE FOR PBC LAYOUT DESIGN

**10.1 Heat dissipation:** The power device needs heat dissipation. The main heat of the chip comes from the power resistor. The power resistor is connected with pin C. Therefore, during PCB wiring, the area of copper foil connected to pin C should be increased and tinned to increase the heat dissipation capacity. It should be properly separated from the transformer and other heating elements to reduce the thermal effect. At the same time, this part is also the part of AC signal, in EMI / EMC design, this position should be far away from the input part as far as possible to reduce the electromagnetic / capacitive coupling;

**10.2** The OC pins is high voltage part of the IC, peak voltage is as high as 600V, so it should be at least 1.5mm far away from the low voltage part (IC, FB, VCC, GND) in the PCB as to avoid circuit breakdown and discharging.

**10.3** Leakage inductance of transformer: since the transformer is not an ideal device, there must be leakage

inductance in the manufacturing process, which will affect the quality and safety of products, so it should be reduced. The leakage inductance should be controlled within 5% of the inductance. P/S/P winding method can reduce the leakage inductance.

## 11. TYPICAL APPLICATION SAMPLE

(12V1.5A OUTPUT FLYBACK TYPE SWITCH MODE POWER SUPPLY)

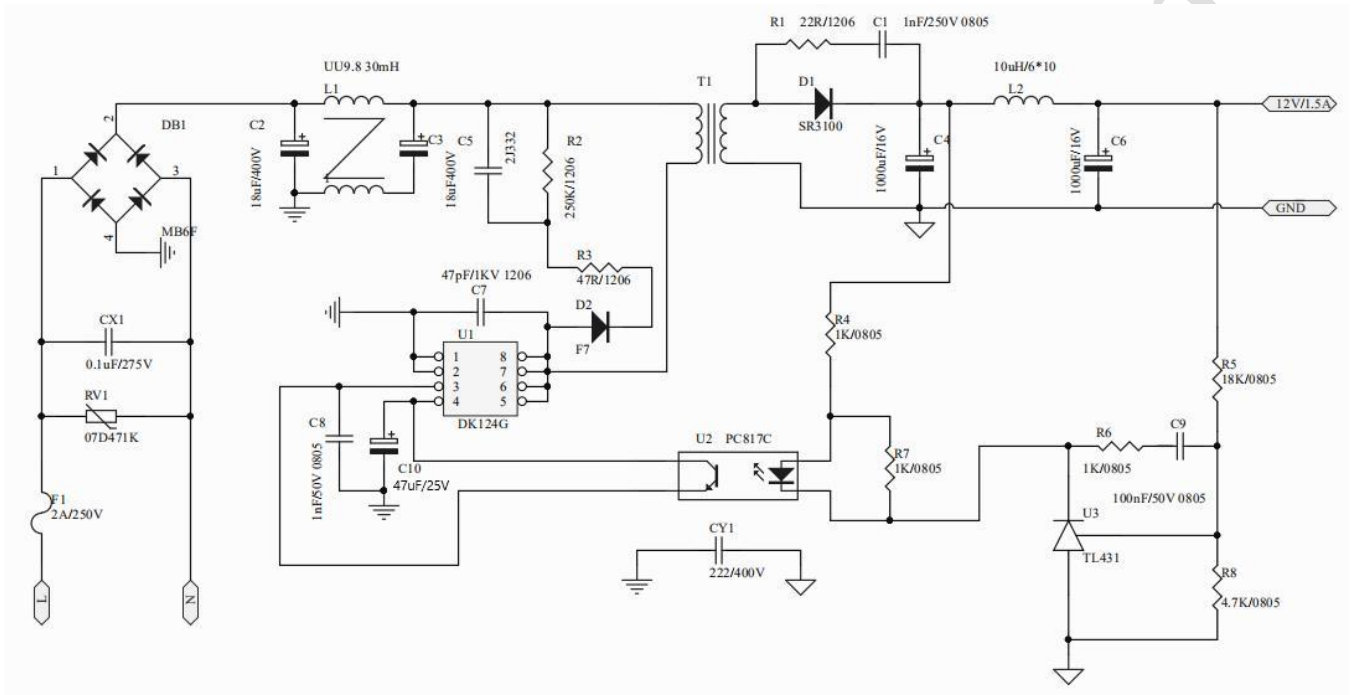

## 12. MECHANICAL AND PACKING INFORMATION

Package type: DIP-8

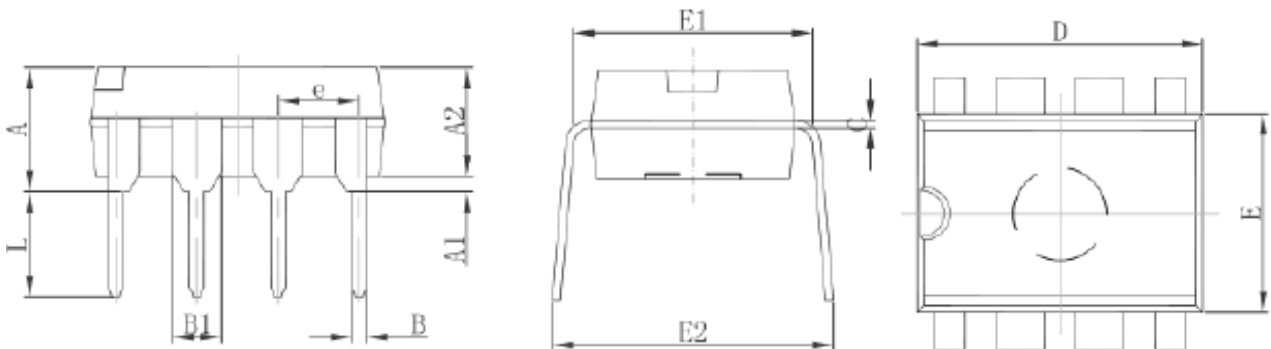

Symbol	Dimensions In Millimeters		Dimensions In Inches	
	Min	Max	Min	Max
A	3.710	4.310	0.146	0.170
A1	0.510		0.020	
A2	3.200	3.600	0.126	0.142
B	0.380	0.570	0.015	0.022
B1	1.524(BSC)		0.060(BSC)	
C	0.204	0.360	0.008	0.014
D	9.000	9.400	0.354	0.370
E	6.200	6.600	0.244	0.260
E1	7.320	7.920	0.288	0.312
e	2.540(BSC)		0.100(BSC)	
L	3.000	3.600	0.118	0.142
E2	8.400	9.200	0.331	0.354

**Packing tube:**

Symbol	Dimensions In Millimeters		
	Min	Rated Value	Max
A	11.00	11.50	12.00
B	11.50	12.00	12.50
C	10.00	10.50	11.00
D	0.40	0.50	0.60
E	3.50	4.00	4.50
F	5.00	5.50	5.10

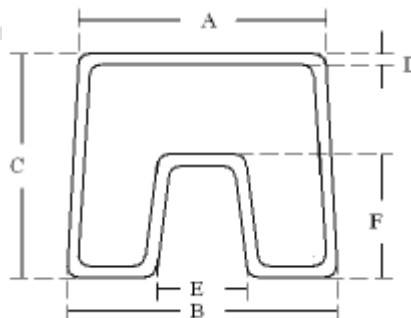
**Packing quantity**

QTY/tube	QTY/inner carton	QTY/master carton
50	2000	20000