

12V/series
40A

SMART MULTI-PURPOSE BATTERY CHARGER

BATTERY MAINTAINER MODEL-DCDS40M



6

STEP

CHARGERS

Step1. Qualification Phase:

Initially ensures that the battery is in good condition prior to charge. As a safety measure charge process will not begin if battery is below 1.5V.

Step2. Recondition Phase:

The reconditioning phase continues to work the battery at a slightly higher voltage and amperage to "re-activate" the battery plates for improve depth of charge and charge acceptance.

Step3. Bulk Charge Phase:

With the battery now through Pulse and reconditioning phases and well on its way to full recovery, the bulk charge phase gives the battery constant current taking the battery up to 80% of its capacity.

Step4. Absorption Phase:

In the absorption phase the battery is given constant voltage while the charge current is gradually reduced according to raise of battery voltage, the charge will stop until the battery is 100% charged.

Step5. Check Phase:

Battery will now checked to be sure that it is holding a charge properly and the charger will make a determination and pass the battery for service, or not

Step6. Maintenance Phase:

The battery charger keeps under control the voltage of the battery.

Descriptions:

Jump monster designs and develops an unique series of smart vehicle battery chargers and special solutions for different battery types (Lead-Acid/AGM/GEL/VRLA/LiON/Calcium) .There are two input ways for your selection ,DC and Solar input , with SOLAR input and DC input protection. Provide a more perfect solution for RV user.

DCDS40M is a 12V/40A DC-DC charger, it can select different batteries through the buttons on the panel. After selecting the charging mode during use, as long as you do not press the Battery Type Selector button, the charger will automatically enter the last selected charging mode each time it is started. To avoid shorten lifespan and encourage life extension of the battery to save the environments, this charger products are programmed to tackle these issues and rejuvenate the fatigued battery to regain back to its peak performance.

Electrical Specifications:

Input Voltage	DC: 12.4V-16V SOLAR: 16V-25V
Output Voltage	14.1VDC-14.7VDC (Lead Acid) 14.4VDC-15.0VDC (AGM/Gel) 15.0VDC-15.8VDC (Calcium) 14.1VDC-14.7VDC (LiON)
Output Current	35.0A~45.0A
Battery type	LEAD-ACID/ AGM / GEL / VRLA/ LiON /Calcium
Operation Temperature	-10°C to 45°C
Warranty	One year

Features :

- Battery mode selection: Lead Acid, AGM/Gel, Calcium, and LiON.
- Automatic power-on voltage specification
- Input reverse Polarity protection
- Output reverse polarity protection
- Last setting memory function
- Output short circuit protection
- Fully charge automatic stop
- Over heat protection
- Trailer/Caravan/RV charger
- 16~25V solar input
- IP65 Waterproof
- MPPT charge controller

Applications:



DONGGUAN ZHONGKANG TECHNOLOGY ELETRONICS CO., LTD
No. 12, Yansha Road, Tianxin, Tangxia Town, Dongguan City, Guangdong Province, China.
Tel: 86-769-8792 7715/6 Fax: 86-769-8798 6887
E-mail: sales@zk-keji.com Web: www.jumpmonster.com



12V/40A

SMART MULTI-PURPOSE BATTERY CHARGER

BATTERY MAINTAINER MODEL-DCDS40M

Mechanical drawings:

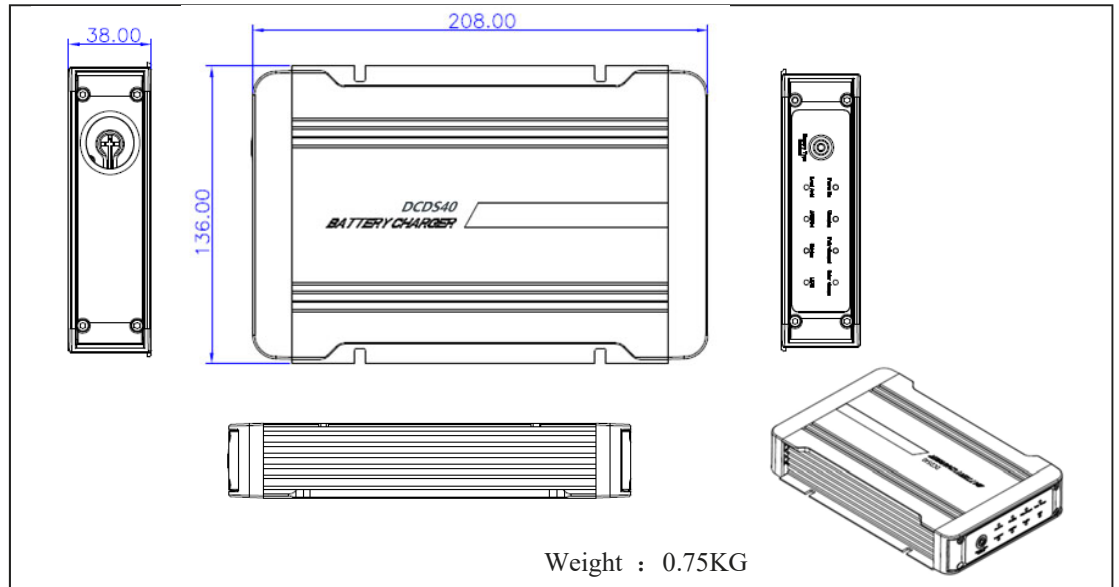

Applications:



Certificates:



Accessories Included:

Standard accessories

TBA

Charging Program:

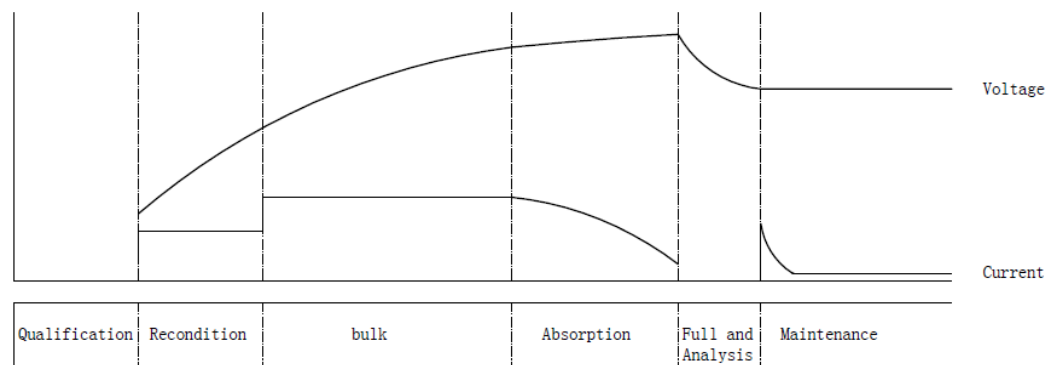

DONGGUAN ZHONGKANG TECHNOLOGY ELETRONICS CO., LTD
 No. 12, Yansha Road, Tianxin, Tangxia Town, Dongguan City, Guangdong Province, China.
 Tel: 86-769-8792 7715/6 Fax: 86-769-8798 6887
 E-mail: sales@zk-keji.com Web: www.jumpmonster.com

* Product specifications may change without notice, please consult the factory.