



PRODUCT GROUP

REV

V1.0

TFT-LCD PRODUCT

Ver.P0

2022.11.01

PRODUCT SPECIFICATION

MODEL: DCE101FHM-N80-700

<◇>PRELIMINARY SPECIFICATION

<◆>APPROVAL SPECIFICATION

CUSTOMER
APPROVED BY
DATE:

DESIGNED	CHECKED	APPROVED



PRODUCT GROUP

REV

V1.0

TFT-LCD PRODUCT

Ver.P0

2022.11.01

REVISION STATUS

Version	Revise Date	Page	Content	Modified by
V1.0	2022.11.01	-	First Issued.	-



PRODUCT GROUP

REV

V1.0

TFT-LCD PRODUCT

Ver.P0

2022.11.01

TABLE OF CONTENTS

No.	CONTENTS	PAGE
	REVISIONSTATUS.....	2
	TABLEOFCONTENTS.....	3
1.	GENERALDESCRIPTION.....	4
2.	MECHANICALSPECIFICATION.....	5
3.	PINDESCRIPTION.....	6
4.	ELECTRICALCHARACTERISTICS.....	7
5.	INPUTSIGNALTIMING.....	9
6.	OPTICALCHARACTERISTICS.....	11
7.	RELIABILITYTESTITEMS.....	14
8.	GENERALPRECAUTION.....	16



PRODUCT GROUP

REV

V1.0

TFT-LCD PRODUCT

Ver.P0

2022.11.01

1.GENERALDESCRIPTION

1.1DESCRIPTION

This LCM is a color active matrix thin film transistor(TFT) IPS liquid crystal display(LCD) that uses amorphous silicon TFT as a switching device.It is composed of a TFT LCD panel, Driver IC,FPC and Backlight,This TFT LCD has a 10.1-inch diagonally measured active display area with(1920 horizontal by 1080 vertical pixel) resolution.

1.2 FEATURES:

No.	Item	Specification	Unit
1	Panel Size	10.1”	inch
2	Number of Pixels	1920×RGB (3)×1080	pixels
3	Active Area	125.712(H)×223.488(V)	mm
4	Pixel Pitch	0.0376(W)×0.1128(V) x RGB	mm
5	Outline Dimension	229.91(W)×135.74(H)×2.8(D)	mm
6	Number of Colors	16.7M	-
7	Display Mode	Transmission mode, normally black	-
8	Viewing Direction	Full viewing	-
9	Display Format	RGB vertical stripe	-
10	Surface Treatment	HC,AG	-
11	Interface	LVDS	-
12	Backlight	White LED	-
13	Operation Temperature	-20°C ~+70°C	°C
14	Storage Temperature	-30°C ~+80°C	°C
15	Aspect Ratio	-	-
16	Weight	TBD	g
17	LED Life-Time	30000	Hour



PRODUCT GROUP

REV

V1.0

TFT-LCD PRODUCT

Ver.P0

2022.11.01

2.MECHANICAL SPECIFICATION

由 Autodesk 教育版产品制作

1. 第三角法

2. Attention to static electricity protection

3. DATE 日期

4. RoHS LCM

5. PAGE 页数 1/1

6. 内容描述

7. 版本

8. 日期

9. 修改原因

10. 内容描述

Notes:

- Unit:mm.
- Do not scale drawing.
- All radii without dimension R0.2.
- Modification Mark.
- draft angle: 1°
- Backlight luminance :750cd/m²(Min), 900cd/m²(Typ)
- Luminance uniformity: 75%(min) (min/max*100%)
- Unspecified Tolerance is ±0.2
- Operation conditions :IF=100mA, VF=54±3V
Color coordinate:X=0.30±0.03, Y=0.30±0.03
- All materials comply with RoHS
- The measured value of luminance and color coordinate bases FX's CA-310
- Check item:1~9

Backlight LED Circuit
9*5=45 LED

模组型号缩减码+年月日+线别+流水号

标签内容

大位号内 九位须跟板位号用

PIN DESCRIPTION

NO.	SYMBOL	DESCRIPTION
1	V(A)	DC GND
2	V/3	DC GND
3	V/6	DC GND
4	L/6	DC GND
5	L/3	DC GND
6	L/A	DC GND
7	V(A)	DC GND
8	V/3	DC GND
9	V/6	DC GND
10	L/6	DC GND
11	L/3	DC GND
12	L/A	DC GND
13	V(A)	DC GND
14	V/3	DC GND
15	V/6	DC GND
16	L/6	DC GND
17	L/3	DC GND
18	L/A	DC GND
19	V(A)	DC GND
20	V/3	DC GND
21	V/6	DC GND
22	L/6	DC GND
23	L/3	DC GND
24	L/A	DC GND
25	V(A)	DC GND
26	V/3	DC GND
27	V/6	DC GND
28	L/6	DC GND
29	L/3	DC GND
30	L/A	DC GND
31	V(A)	DC GND
32	V/3	DC GND
33	V/6	DC GND
34	L/6	DC GND
35	L/3	DC GND
36	L/A	DC GND
37	V(A)	DC GND
38	V/3	DC GND
39	V/6	DC GND
40	L/6	DC GND
41	L/3	DC GND
42	L/A	DC GND
43	V(A)	DC GND
44	V/3	DC GND
45	V/6	DC GND
46	L/6	DC GND
47	L/3	DC GND
48	L/A	DC GND
49	V(A)	DC GND
50	V/3	DC GND
51	V/6	DC GND
52	L/6	DC GND
53	L/3	DC GND
54	L/A	DC GND
55	V(A)	DC GND
56	V/3	DC GND
57	V/6	DC GND
58	L/6	DC GND
59	L/3	DC GND
60	L/A	DC GND
61	V(A)	DC GND
62	V/3	DC GND
63	V/6	DC GND
64	L/6	DC GND
65	L/3	DC GND
66	L/A	DC GND
67	V(A)	DC GND
68	V/3	DC GND
69	V/6	DC GND
70	L/6	DC GND
71	L/3	DC GND
72	L/A	DC GND
73	V(A)	DC GND
74	V/3	DC GND
75	V/6	DC GND
76	L/6	DC GND
77	L/3	DC GND
78	L/A	DC GND
79	V(A)	DC GND
80	V/3	DC GND
81	V/6	DC GND
82	L/6	DC GND
83	L/3	DC GND
84	L/A	DC GND
85	V(A)	DC GND
86	V/3	DC GND
87	V/6	DC GND
88	L/6	DC GND
89	L/3	DC GND
90	L/A	DC GND
91	V(A)	DC GND
92	V/3	DC GND
93	V/6	DC GND
94	L/6	DC GND
95	L/3	DC GND
96	L/A	DC GND
97	V(A)	DC GND
98	V/3	DC GND
99	V/6	DC GND
100	L/6	DC GND
101	L/3	DC GND
102	L/A	DC GND
103	V(A)	DC GND
104	V/3	DC GND
105	V/6	DC GND
106	L/6	DC GND
107	L/3	DC GND
108	L/A	DC GND
109	V(A)	DC GND
110	V/3	DC GND
111	V/6	DC GND
112	L/6	DC GND
113	L/3	DC GND
114	L/A	DC GND
115	V(A)	DC GND
116	V/3	DC GND
117	V/6	DC GND
118	L/6	DC GND
119	L/3	DC GND
120	L/A	DC GND

图 式 正

SCALE 1:1

DATE 2022-11-01

APPROVED BY: CHENGP BY: DAANY BY



PRODUCT GROUP

REV

V1.0

TFT-LCD PRODUCT

Ver.P0

2022.11.01

3.PIN DESCRIPTION

No.	Symbol	Function	Remark
1	VLED-	LED Cathode	
2	VLED-	LED Cathode	
3	VLED+	LED Anode	
4	VLED+	LED Anode	
5	GND	Ground	
6	OD0N	- LVDS differential data 0(ODD)	
7	OD0P	+ LVDS differential data 0(ODD)	
8	GND	Ground	
9	OD1N	- LVDS differential data 1(ODD)	
10	OD1P	+ LVDS differential data 1(ODD)	
11	GND	Ground	
12	OCLKN	- LVDS differential clock(ODD)	
13	OCLKP	+ LVDS differential clock(ODD)	
14	GND	Ground	
15	OD2N	- LVDS differential data 2(ODD)	
16	OD2P	+ LVDS differential data 2(ODD)	
17	GND	Ground	
18	OD3N	- LVDS differential data 3(ODD)	
19	OD3P	+ LVDS differential data 3(ODD)	
20	GND	Ground	
21	ED0N	- LVDS differential data 0(EVEN)	
22	ED0P	+ LVDS differential data 0(EVEN)	
23	GND	Ground	
24	ED1N	- LVDS differential data 1(EVEN)	
25	ED1P	+ LVDS differential data 1(EVEN)	
26	GND	Ground	
27	ECLKN	- LVDS differential clock(EVEN)	
28	ECLKP	+ LVDS differential clock(EVEN)	
29	GND	Ground	
30	ED2N	- LVDS differential data 2(EVEN)	
31	ED2P	+ LVDS differential data 2(EVEN)	
32	GND	Ground	
33	ED3N	- LVDS differential data 3(EVEN)	
34	ED3P	+ LVDS differential data 3(EVEN)	
35	STBYB	Stbyb Pin,Low active	
36	I2C_SDA	Serial address and data for I2C	
37	I2C_SCL	Clock signal for I2C interface	
38	RESET	Reset Pin,Low active	
39	VDDIN	Power supply VDDIN=3.3(TYP)	
40	VDDIN	Power supply VDDIN=3.3(TYP)	

4. ELECTRICAL CHARACTERISTICS

4.1 ELECTROMAGNETIC TOUCH BOARD

Parameter	Symbol	Condition	Spec			Unit
			Min	Typ	Max	
Differential input high Threshold Voltage	Vth	Vcm=1.2V	-	-	+0.1	V
Differential input low Threshold Voltage	Vtl	-	-0.1	-	-	V
Differential input common Mode Voltage	Vcm	-	1	1.2	$1.7 - V_{id} /2$	V
LVDS input voltage	Vinlv	-	0.7	-	1.7	V
Different input voltage	Vid	-	0.1	-	0.6	V
Differernt input leakage Current	Ilvleak	-	-10	-	+10	uA

< Table7. LVDS mode DC electrical characteristics >

Single-ended:

LVCLKP (R),
LVCLKN (R),
LVD[3:0]P (R),
LVD[3:0]N (R)

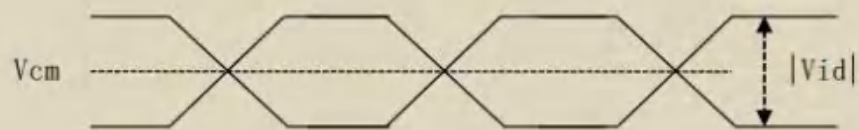

Differential:
LVCLKP (R) - LVCLKN (R),
LVD[3:0]P (R) -
LVD[3:0]N (R)

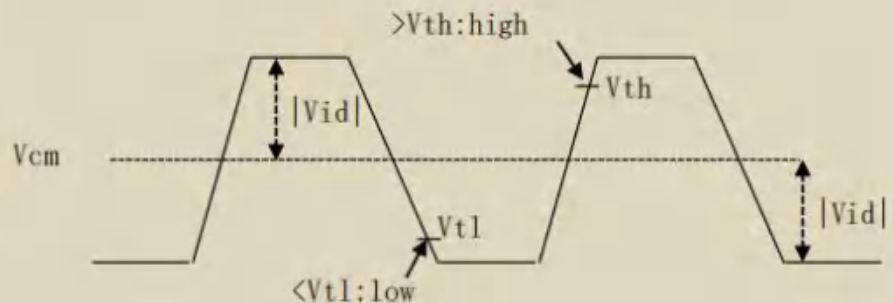

4.2 TFT LCD MODULE

< Table 4. LCD Module Electrical specifications > [Ta=25±2°C]

Parameter	Symbol	Values			Unit	Notes
		Min.	Typ.	Max.		
Power Supply Voltage	VDDIN	3.0	3.3	3.6	V	
Power Supply Current	IDDIN	-	-	-	mA	Note 1
Power Consumption	PLCD	-	-	-	W	
Rush current	IRUSH	-	-	-	A	Note 2

Notes : 1. The supply voltage is measured and specified at the interface connector of LCM.
 The current draw and power consumption specified is for VDD=3.3V, Frame rate $f_v=60\text{Hz}$
 Test Pattern of power supply current

a) Typ : Mosaic 5 x 5 Pattern(L0/L255)



b) Max : skip column (L0/L255)

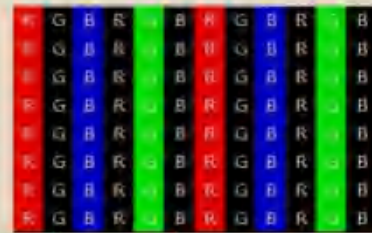

2. The duration of rush current is about 2ms and rising time of Power Input is 1ms(min)

4.3 BACKLIGHT UNIT

Item	Symbol	Values			Unit	Remark
		Min.	Typ.	Max.		
LED Current	Iled	-	100	-	mA	Total LED
Forward voltage	VF	-	54	-	V	IF=100mA
Reverse current	IR	-	-	50	μA	VR=5V, 1LED
Power dissipation	Pd	5400			mW	Total LED
Peak forward current	IFP	100			mA	1LED
Reverse Voltage	VR	5			V	1LED

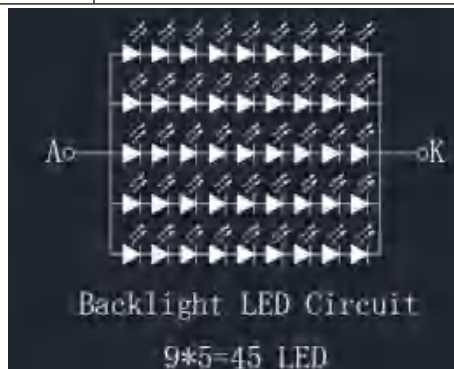



5. INPUT SIGNAL TIMING

5.1 Interface timing parameter

< Table8. SSC limitation of LVDS interface >

Parameter	Symbol	condition	Spec			Unit
			Min.	Typ.	Max	
Modulation frequency	SSCmf	LVDS clock frequency center at 80MHZ	-	-	200	KHZ
		LVDS clock frequency center at 60MHZ	-	-	150	KHZ
		LVDS clock frequency center at 40MHZ	-	-	100	KHZ
		LVDS clock frequency center at 20MHZ	-	-	50	KHZ
Modulation rate	SSCmr	LVDS clock frequency +SSCMR in the range of 20MHZ~80MHZ	-	-	±3	%

< Table9. Timing Parameter >

Item		Symbol	min	typ	max	UNIT	
LCD	Frame Rate	-	-	60	-	Hz	
Timing	DCLK	Frequency	fCLK	68.4	-	MHz	
	Horizontal	Horizontal total time	tHP	-	1014	-	t _{CLK}
		Horizontal Valid data	thd	960			t _{CLK}
		Horizontal Pulse Width	tHsync	-	12	-	t _{CLK}
		Horizontal Back Porch	tHBP	-	16	-	t _{CLK}
		Horizontal Front Porch	tHFP	-	38	-	t _{CLK}
	Vertical	Vertical total time	tvp	-	1124	-	t _H
		Vertical Valid time	tvd	1080			t _H
		Vertical Pulse Width	tVsync	-	5	-	t _H
		Vertical Back Porch	tVBP	-	24	-	t _H
Vertical Front Porch		tVFP	-	20	-	t _H	

5.2 Power Sequence

To prevent a latch-up or DC operation of the LCD module, the power on/off sequence shall be as shown in below.

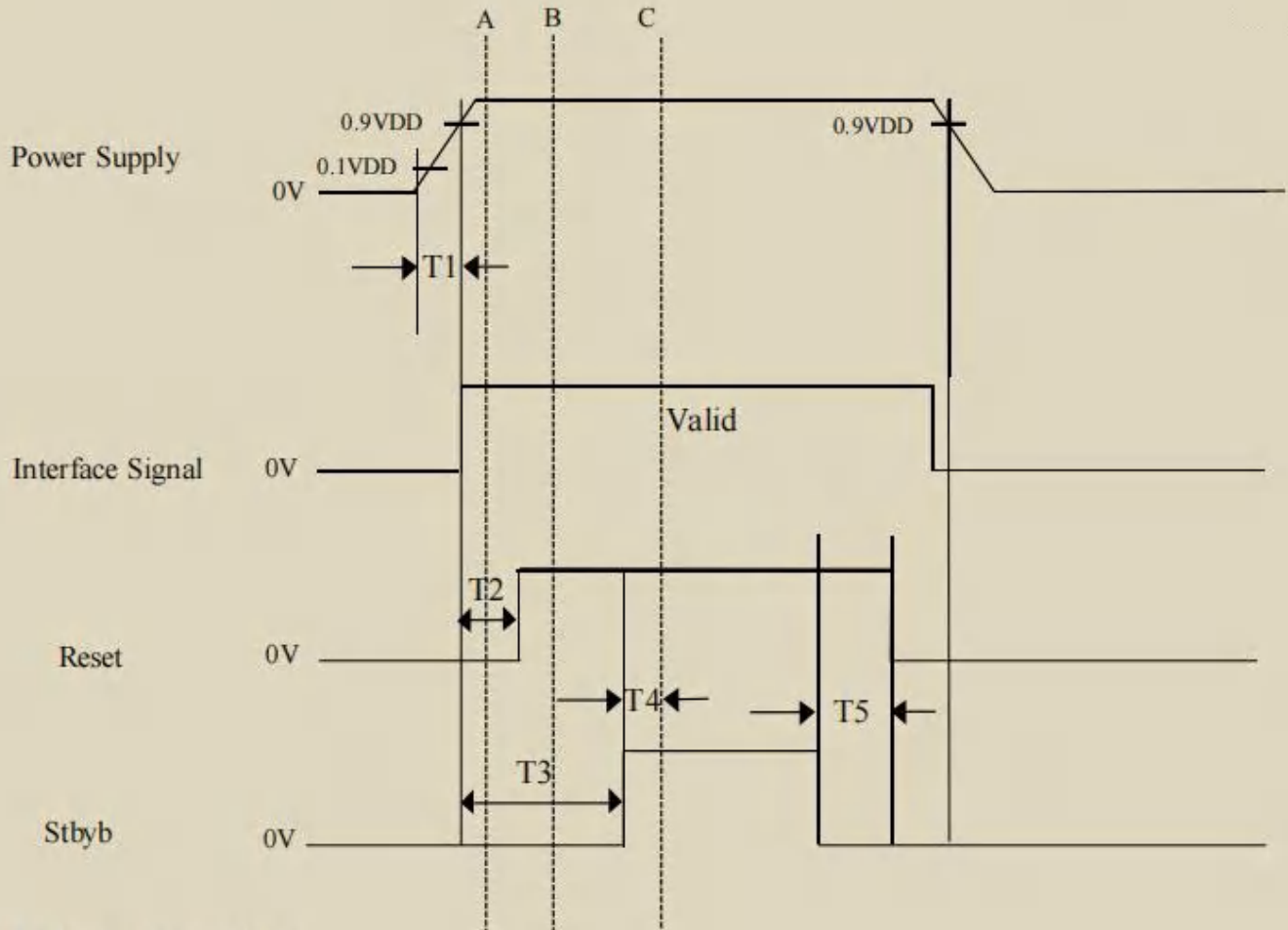

- $0.5\text{ ms} < T1 < 10\text{ ms}$
- $T2 > 10\text{ us}$
- $T3 > 16\text{ ms}$
- $T4 < 150\text{ ms}$
- $T5 > 90\text{ ms}$

Notes:

1. The valid LVDS signals (clock pair and all data pairs in toggling state) must be consistent with panel resolution and suggestions.
2. The application system can apply LVDS signals from point A (VCC1 is ready and not reset completed) , B (reset completed and in standby mode) , or C (reset completed and non-standby mode)

6. OPTICAL CHARACTERISTICS

Item	Symbol	Min.	Typ.	Max.	Unit	Note	
Contrast Ratio	CR	800	1000	-		Note1 Note3	
Luminance(center)	L	670	700	-	cd/m2	Note1 Note5 Note7	
Luminous tolerance	LU	75	80		%	Note7	
Response Time	Rising + Falling	-	25	35	ms	Note1 Note4	
Viewing Angle K=Contrast Ratio>10	Horizontal	θ_{x^+}	75	80	-	degree	Note2
		θ_{x^-}	75	80	-		
	Vertical	θ_{y^+}	75	80	-		
		θ_{y^-}	75	80	-		
Color Chromaticity (CIE1931)	Red	x	Typ- 0.03	0.	Typ+ 0.03	Note1 Note5 Note7	
		y		660.			
	Green	x		310.			
		y		250.			
	Blue	x		650.			
		y		140.			
	White	x		070.			
		y		300.			
0Color gamut (NTSC ratio)		85	30		%		

Note1: Definition of optical measurement system (BM-7)

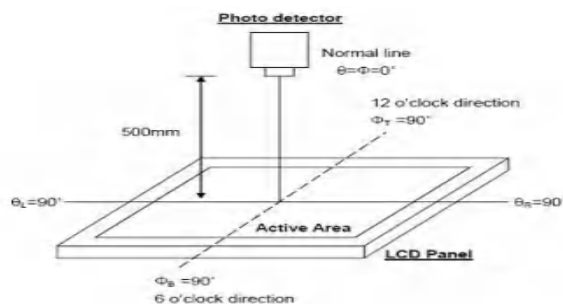

Note2: Definition of viewing angle range and measurement system

Viewing angle is measured at the center point of the LCD by CONOSCOPE (ergo-80).

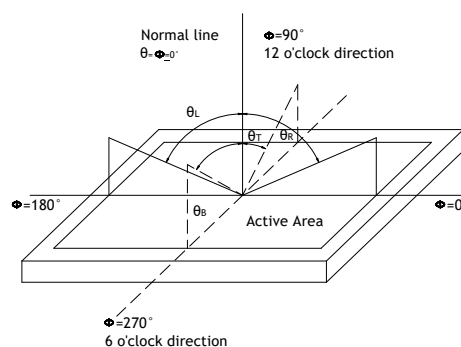

Note3: Definition of Response time

The response time is defined as the LCD optical switching time interval between “White” state and “Black” state. Rise time (TON) is the time between photo detector output intensity changed from 90% to 10%. And fall time (TOFF) is the time between photo detector output intensity changed from 10% to 90%.

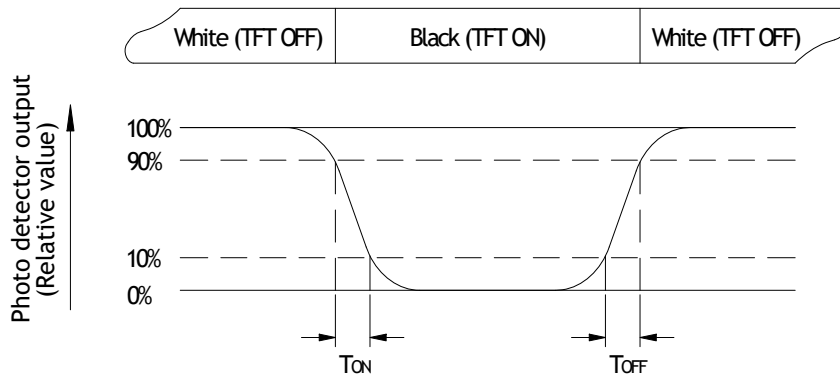

Fig. 6-3 Definition of response time

Note4: Definition of contrast ratio

$$\text{Contrast ratio(CR)} = \frac{\text{Luminance measured when LCD on the Whitestate}}{\text{Luminance measured when LCD on the Blackstate}}$$

“White state “: The state is that the LCD should drive by Vwhite.

“Black state”: The state is that the LCD should drive by Vblack.

Vwhite: To be determined Vblack: To be determined.

Note5: Definition of color chromaticity (CIE1931)

Color coordinates measured at center point of LCD.

Note6: All input terminals LCD panel must be ground while measuring the center area of the panel. The LED driving condition is IL=100mA

Note7: Definition of Luminance Uniformity

Active area is divided into 9 measuring areas. Every measuring point is placed at the center of each measuring area.

$$\text{Luminance Uniformity (U)} = \text{Lmin} / \text{Lmax}$$

L----Active area length, W---- Active area width

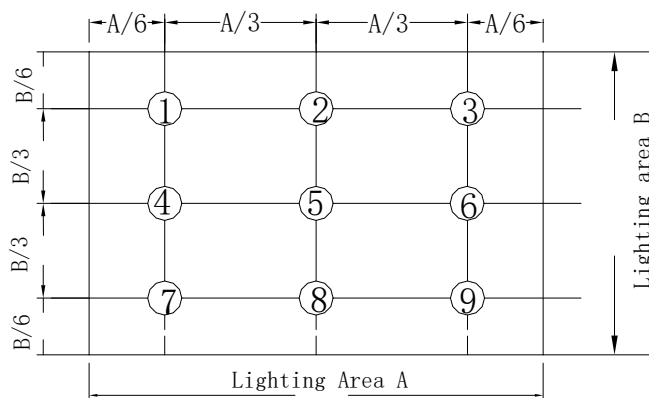

Bmax: The measured maximum luminance of all measurement position.

Bmin: The measured minimum luminance of all measurement position.

7. RELIABILITY TEST ITEMS

Test Item	Test Condition	Remark
High Temperature Storage	Ta=80℃; 240hrs	IEC60068-2-1: 2007 GB2423.2-2008
Low Temperature Storage	Ta=-30℃;240hrs	IEC60068-2-1: 2007 GB2423.1-2008
High Temperature Operation	Ta=70℃; 240Hrs	IEC60068-2-1: 2007 GB2423.2-2008
Low Temperature Operation	Ta=-20℃; 240hrs	IEC60068-2-1: 2007 GB2423.1-2008
High Temperature High Humidity Operation	Ta=50℃, 90%RH, 96Hrs(no condensation)	IEC60068-2-78: 2001 GB/T2423.3-2006
Thermal Shock	-20℃(0.5h) ~ 70℃(0.5h) / 72 cycles	Start with cold temperature , End with high temperature, IEC60068-2-14:1984,GB2423.22-2002
Image Sticking	25℃ ; 1hrs	-

Note1:Condition of image sticking test :25℃±2℃

Operation with test pattern sustained for 1 hrs,then change to gray pattern immediately.after 5 mins,the mura must be disappeared completely

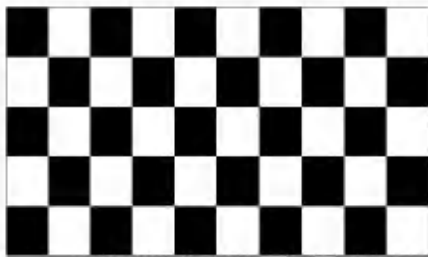

(a) Test Pattern (chess board Pattern)

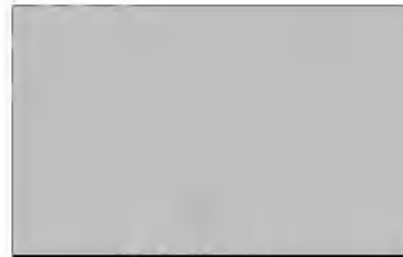

(b) Gray Pattern

7.2 VIBRATION&SHOCK

Test item	Conditions	Remark
Packing Shock (non-operation)	980m/s ² ,6ms, ±x,y,z 3times for direction	IEC60068-2-27: 1987 GB/T2423.5-1995
Packing Vibration (non-operation)	Frequency range:10 HZ~50HZ Stroke:1.0mm,sweep:10 HZ ~50HZ x,y,z 2 hours for each direction	IEC60068-2-32: 1990 GB/T2423.8-1995

7.3 ESD

Test item	Conditions	Remark	
Electro Static Discharge Test (non-operation)	150pF, 330Ω, Contact:±4KV,Air:±8KV	1	Class C
	200pF, 0Ω, ±200V contact test	2	

Note: Measure point :

- LCD glass and metal bezel
- IF connector pins
- ESD class B:some performance degradation allowed. Self-recoverable.
No data lost,no hardware failures.

8. GENERAL PRECAUTION



PRODUCT GROUP

REV

V1.0

TFT-LCD PRODUCT

Ver.P0

2022.11.01

8.1 SAFETY

1. Do not swallow any liquid crystal, even if there is no proof that liquid crystal is poisonous.
2. If the LCD panel breaks, be careful not to get liquid crystal to touch your skin.
3. If skin is exposed to liquid crystal, wash the area thoroughly with alcohol or soap.

8.2 STORAGE CONDITIONS

1. Store the panel or module in a dark place where the temperature is $23\pm 5^{\circ}\text{C}$ and The humidity is below $50\pm 20\%RH$.
2. Store in anti-static electricity container.
3. Store in clean environment, free from dust, active gas, and solvent.
4. Do not place the module near organics solvents or corrosive gases.
5. Do not crush, shake, or jolt the module.

8.3 HANDLING PRECAUTIONS

1. Avoid static electricity which can damage the CMOS LSI.
2. The polarizing plate of the display is very fragile. So, please handle it very carefully.
3. Do not give external shock.
4. Do not apply excessive force on the surface.
5. Do not wipe the polarizing plate with a dry cloth, as it may easily scratch the Surface of plate.
6. Do not use ketonics solvent & Aromatic solvent, use with a soft cloth soaked with a cleaning naphtha solvent.
7. Do not operate it above the absolute maximum rating.
8. Do not remove the panel or frame from the module.
9. When the module is assembled, it should be attached to the system firmly, Be careful not to twist and bend the module.
10. Wipe off water droplets or oil immediately. If you leave the droplets for a long time, staining and discoloration may occur.
11. If the liquid crystal material leaks from the panel, it should be kept away from the eyes or mouth in case of contact with hands, legs or clothes, it must be washed away thoroughly with soap.

8.4 WARRANTY

1. The period is within twelve months since the date of shipping out under normal using and storage conditions.
2. Do not repaired or modified the LCM. It may cause function to lose efficacy, Starry does not warrant the LCM.
3. All process and material comply ROHS.