



Lsleds

IP66 400W Flood Light Specification

LS-FLN400

LS-FLN400-HI



V 1.3

Lg`YXg Technology

Co., Ltd.

IP66 400 watt Flood Light

Feature:

- * Brightest Flood Light in the world!
- * Premium Precise Optical Lens System, 2-10 times brighter than conventional light
- * Modular Design, Easier Maintenance
- * Direct Heat Path Technology, 2-5 times better stability
- * Anti-Glare System, suitable for any occasions
- * IP66, underwater use support
- * 3 Years Warranty!

TECHNICAL PARAMETER

ITEM	IP66 Waterproof LED Lamp	
ITEM NO	LS-FLN400	LS-FLN400-Hi
Power	400W	400W
Light Source	Epistar /Brigelux Power /Cree Chip	Epistar /Brigelux Power Chip
Input Voltage	90-265VAC 50-60HZ	90-265VAC 50-60HZ
Power Factor (PF)	≥0.95	≥0.95
Power Efficiency	≥90%	≥90%
Color Index(CRI)	Ra>70	Ra>70
Light Angle	10°, 25°, 40°, 60°, 90°	25°,40°,60°,90°
Color Temp:	2700-3500K 5000-6500K 6500-7500K	2700-3500K 5000-6500K 6500-7500K
LED Luminous Efficiency	100lm / Watt	140lm / Watt
Luminous Flux (Typ.)	40000lm	52000lm
Equal Flux (Typ.) *	80000lm	104000lm
Life Span	≥80000 hours	≥80000 hours
Work Temperature:	- 40 ° C ~ 60 ° C	- 40 ° C ~ 60 ° C
Storage Temperature:	- 50 ° C ~ 80 ° C	- 50 ° C ~ 80 ° C
Working Humidity	10 % ~ 90 % RH	10 % ~ 90 % RH
IP Rating	IP66	IP66
Light Attenuation(80000h)	30%	30%
Light Body Size (LxWxH)	570x416.5x90mm	570x416.5x90mm
Lamp Net Weight(KG)	16	16
Package Size:	620x480x285 mm	620x480x285 mm

Luminance Indication (Center Lux)

Total Weight (KG)	27		27
-------------------	----	--	----

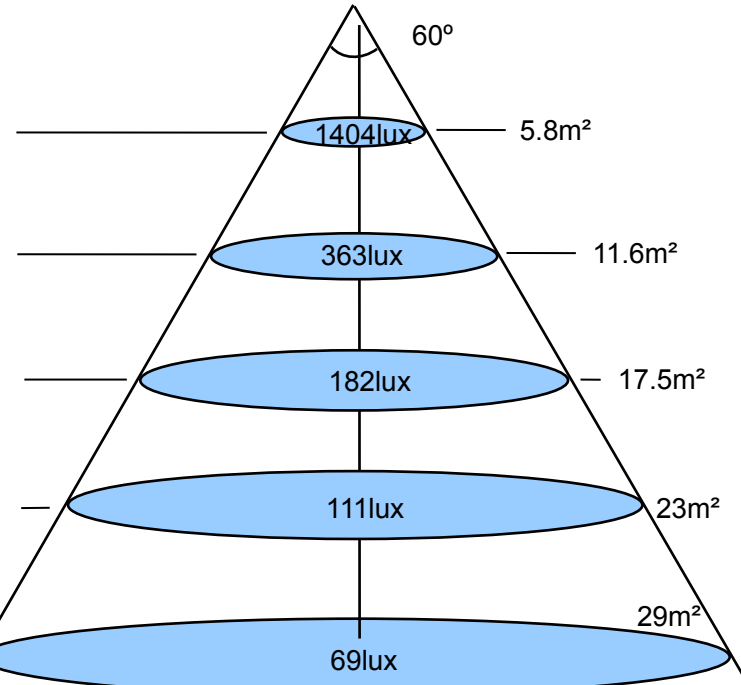
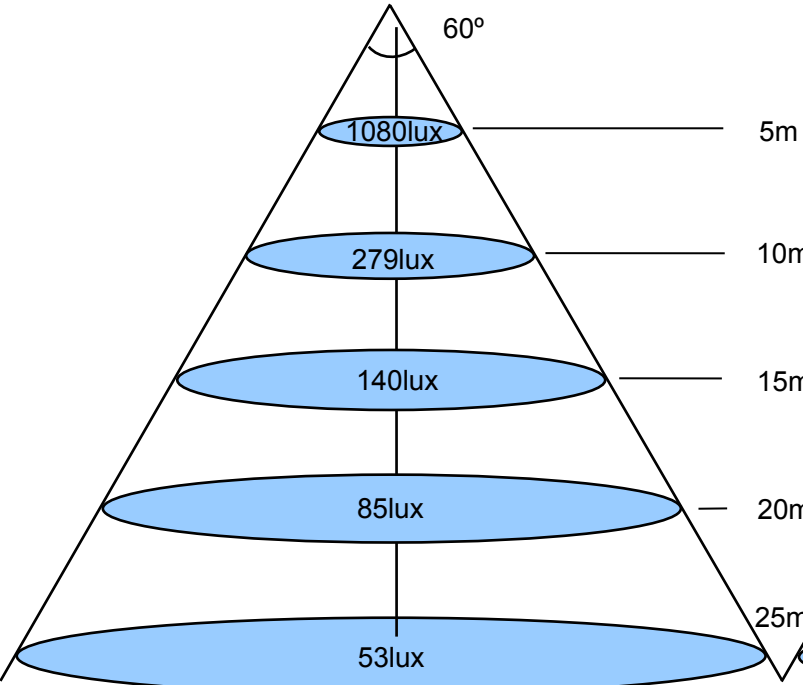
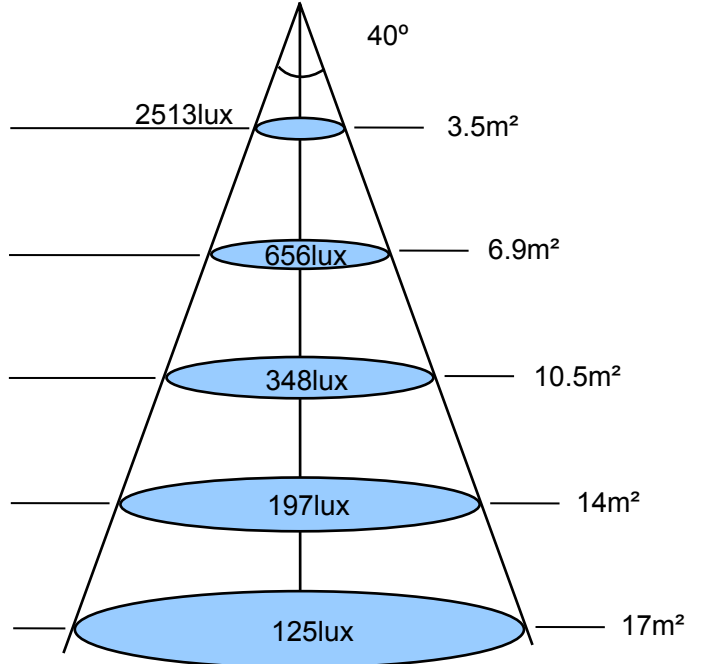
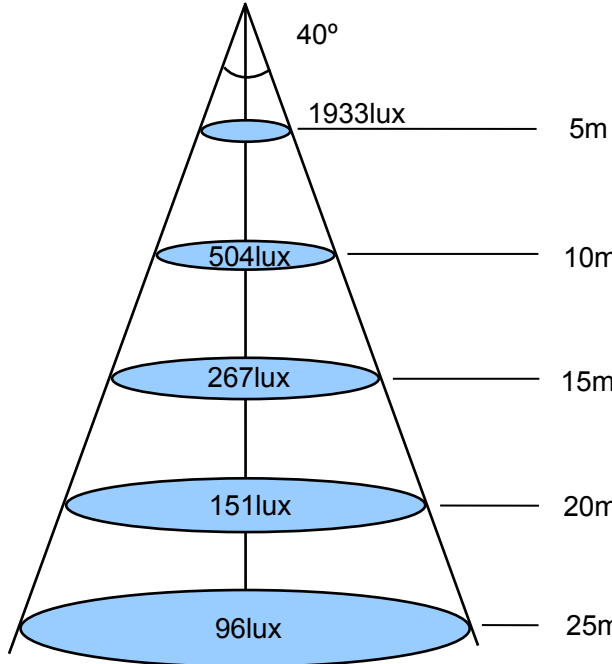
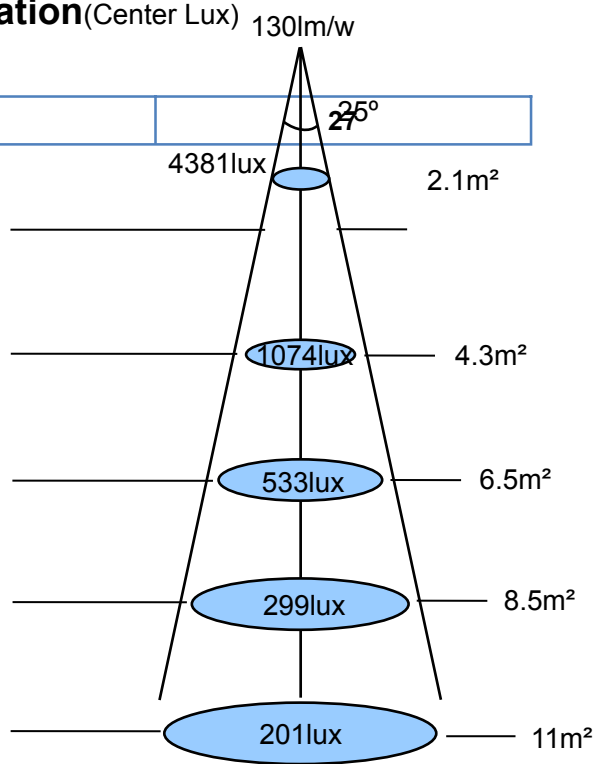
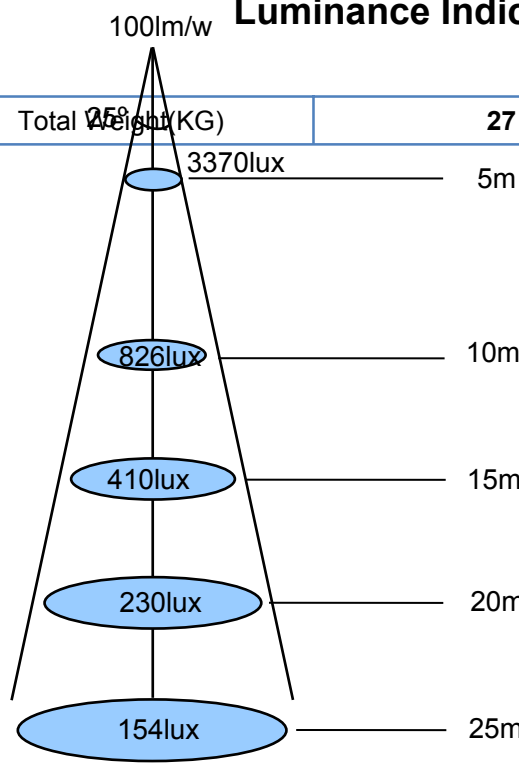

Product Dimensions (Size units: millimetre)

138 ° Angle rotated

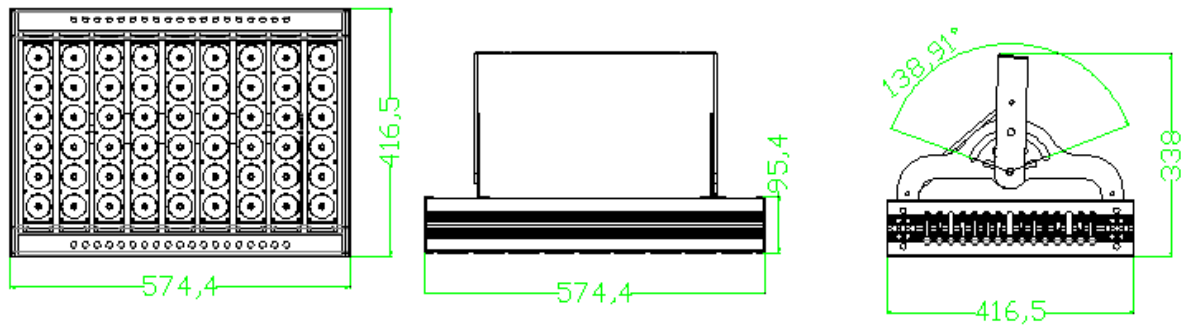

Package Dimensions

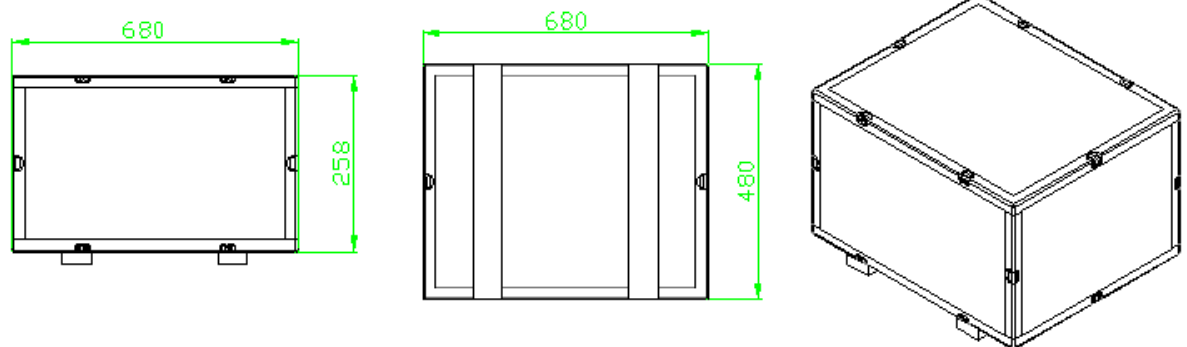

Packaging process

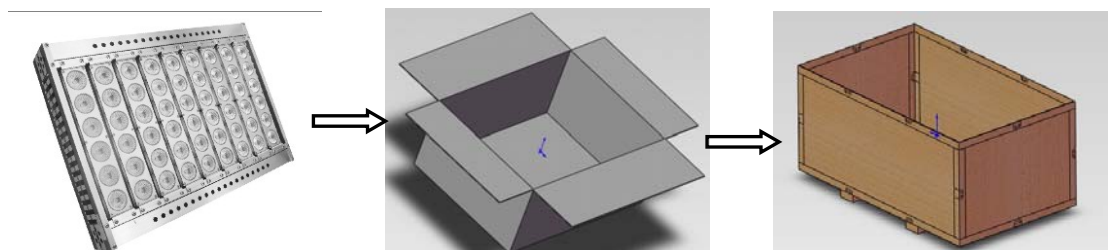

1000W LED Flood Light Test Report

Test Item: 1000Watt Flood Light

Test Company: Independent Laboratory Testing

Test Date: From Feb.1st 2011 to Oct 11st 2011

1. Life Span Test Project

Test Method:

Light Fixture maintains bright in constant temperature and humidity environment, temperature range should be within 45+/-2 degree, relative humidity is no more than 60% ,wind speed is less than 0.05m/s. Light Fixture is driven of the constant temperature and humidity environment, adjust the ambient temperature to 25+/-2 degree. The measure it with power

Test data:

Hour(H)	Light Flux(LM)	DC Voltage	DC Current(A)	Preservation Rate of light
1	110000lm	31.33	35	100%
1000	107800lm	31.35	35	98%
2000	107360lm	31.30	35	97.6%
3000	106150lm	31.35	35	96.5%
5000	104500lm	31.28	35	95%
6000	103730lm	31.37	35	94.3%
6500	102850lm	31.37	35	93.5%

Estimated life Span:

According To energy star requirements for LED life Spain, light saving rate is 93.50% for 6500hours and life span is greater than 80000 hours

Failure Determined:

When retention rate is less than 70%, we regard it as led failure. The Visible brightness is observed obviously down, central color temperature shifts seriously, the basic lighting requirements for customers or Users can not be satisfied, or it has bad effect to the eyes of users. Failure time: generally 100000hours.

2. Opto-electric test project:

Lamp Parameters:

Input Power AC(W)	Rated	1050
	Measured	1049
Power Factor	Rated	0.95
	Measured	0.95
Input Frequency (HZ)	Rated	50~60
	Measured	50
Color Temperature (K)	Rated	2800-7500
	Measured	6750
Luminous Flux (lm)	Rated	110000
	Measured	115400
Input Voltage (V)	Rated	30-34
	Measured	31.3
Input Current (A)	Rated	35
	Measured	35
Luminary Efficiency (lm/W)	Rated	110
	Measured	115
Color Index (RA)	Rated	70
	Measured	74.5

Test Instruction

1. The Luminous surface of fixture is horizontal
2. LED Driver is inbuilt type.
3. Light Source: LS-HPEPY100M50CW-A11 10pcs
4. Keep the light on for 2 hours when measured; write down the numbers after the light source is stable
5. Test Environment temperature: 25+/-1C, Humidity: 61+/-10% RH
6. Photometric Test Condition: Use The Sphere- Radiometer to test optical and color Parameters: Integrating sphere diameter-1.5, inner ball coating is barium sulfate, reflection rate 90-95% . Measuring method-4%,the spectrum range is 380-790nm
7. Uncertainty explanation: under impact from test environment and temperature, the system inaccuracy of testing instruments will further impact the test results

Referred test standard: IES LM-78:2008, IES LM-79:2008, IES LM-80: 2008,
US Energy star, LED TEST(Version 2),CIE 127:2007,ISBN 978 3 901 906 589

10 years of experience on LED Illumination

We have supplied solutions for companies like Ericsson &

Elextrolux over 6 years

We do no copy, we do independent R&D

Super LED Flood Light

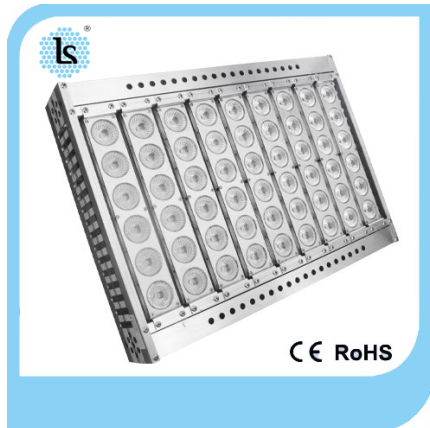

Super LED Billboard Light



Super LED High Bay light

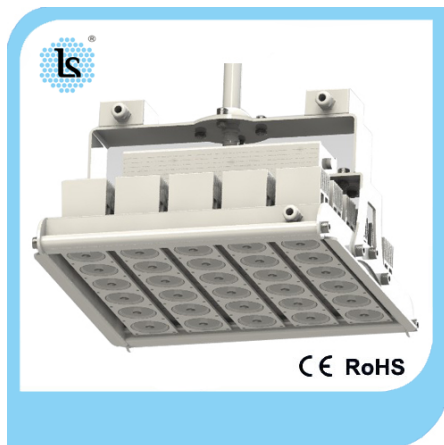

Super Strip LED Floodlight



Lsleds Technology Co., Ltd

Web:www.lsleds.com

Email: ellen0306@vip.163.com

Tel:86-755-83980579

Fax:86-755-83980571

Mobile: +86-13808856867

Skype:[ellen030688](https://www.skype.com/en/contacts/ellen030688)