

## D Series Air Cooler

### Features

1. Cabinet of steel plate with plastic spray, corrosion proof and pleasant looking.
2. Mechanically expanded pipes with AL fins with good transfer performance.
3. Inside are evenly arranged with defrosting heater.
4. The bottom has double water receivers, effective for anti-freezing.
5. Long distance air throw is optional.



### Features

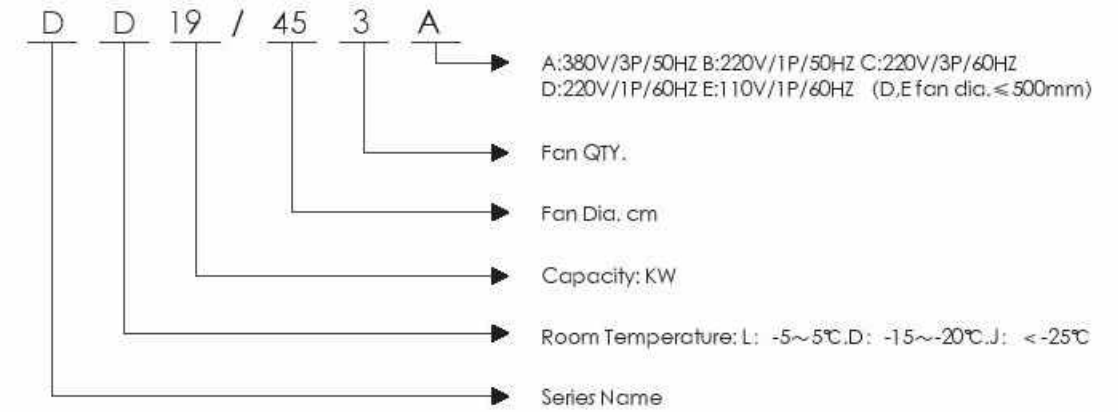

### Specification

#### 1. DL Models ( Fin Spcce 4.5mm)

型号 Model	Capacity kw DT=7K t0=-7°C		Air flow m³/h	Air throw m	Fan input W	Defrosting(KW)		Overall size(mm)										Pipe dia. mm		Drainage
	R22	R404A				Coil	Water Receiver	A	B	C	D	E	E1	E2	E3	F	Liquid	Gcs		
DL2.2/311A	2.2	2.3	1500	9	90	1	0.5	642	445	465	364	440	-	-	-	105	φ12.7	φ12.7	1"	
DL3.5/311A	3.5	3.7	1500	9	90	1.5	0.5	642	445	465	364	440	-	-	-	105	φ12.7	φ19	1"	
DL4.7/312A	4.7	4.9	3000	9	180	1.8	0.9	1092	445	465	364	860	-	-	-	120	φ12.7	φ22	1"	
DL6/312A	6	6.3	3000	9	180	2.7	0.9	1108	455	465	384	860	-	-	-	120	φ12.7	φ22	1"	
DL9/352A	9	9.5	4500	10	280	2.7	0.9	1408	455	465	384	1160	-	-	-	135	φ16	φ22	1"	
DL12.5/402A	12.5	13.1	7000	13	360	3.6	1.2	1488	555	565	484	1240	-	-	-	135	φ16	φ22	1"	
DL14.5/402A	14.5	15.2	7000	13	360	4.8	1.2	1488	555	665	484	1240	-	-	-	135	φ16	φ28	1"	
DL17/402A	17	17.9	7000	13	360	6	1.2	1488	555	565	484	1240	-	-	-	135	φ16	φ28	1"	
DL25/502A	25	26.3	12000	17	900	7.5	1.5	1758	555	665	484	1480	-	-	-	135	φ22	φ35	1"	
DL29/453A	29	30.5	13500	17	750	8	2	2121	595	665	502	1801	627	587	-	160	φ22	φ35	1"	
DL36.5/503A	36.5	38.3	18000	19	1350	8	2	2400	595	665	502	2080	720	680	-	160	φ22	φ42	1"	
DL42/503A	42	44.1	18000	19	1350	10	2	2704	595	665	502	2374	818	778	-	160	φ22	φ42	1"	
DL49/503A	49	51.5	18000	19	1350	12	2	2704	595	665	502	2374	818	778	-	160	φ22	φ54	1"	
DL59/504A	59	62	24000	19	1800	13	2.6	3938	785	675	682	3600	930	885	895	170	φ22	φ54	1"	
DL70/554A	70	73.5	30000	25	2400	15.6	2.6	3938	785	775	682	3600	930	885	895	170	φ22	φ54	1"	
DL84/554A	84	88.2	30000	25	2400	18.6	2.6	3978	785	975	682	3600	930	885	895	170	φ28	φ54	1"	
DL103/604A	103	108.2	42000	25	3120	20.8	2.6	3978	785	1175	682	3600	930	885	895	170	φ28	φ60	1"	
DL112/634A	112	117.6	46000	25	3200	23.4	5.2	3988	785	1275	682	3620	950	890	890	170	φ35	φ60	1"	
DL122/634A	122	128.1	46000	28	3200	26	5.2	3988	785	1375	682	3620	950	890	890	170	φ35	φ60	1"	

## D Series Air Cooler

### 2、DD Models ( Fin Spcce 6.0 mm)

型号 Model	Capacity kw DT=7K t0=-7℃		Air flow m³/h	Air throw m	Fcn input W	Defrosting(KW)		Overall size(mm)										Pipe dia. mm		Drainage
	R22	R404A				Coil	Water Receiver	A	B	C	D	E	E1	E2	E3	F	Liquid	Gcs		
DD1.4/311A	1.4	1.5	1500	9	90	1	0.5	642	445	465	364	440	-	-	-	105	φ12.7	φ12.7	1"	
DD2.3/311A	2.3	2.4	1500	9	90	1.5	0.5	642	445	465	364	440	-	-	-	105	φ12.7	φ19	1"	
DD3/312A	3	3.2	3000	9	180	1.8	0.9	1092	445	465	364	860	-	-	-	120	φ12.7	φ22	1"	
DD4.5/312A	4.5	4.7	3000	9	180	2.7	0.9	1108	455	465	384	860	-	-	-	120	φ12.7	φ22	1"	
DD6/352A	6	6.3	4500	10	280	2.7	0.9	1408	455	465	384	1160	-	-	-	135	φ16	φ22	1"	
DD7.5/402A	7.5	7.9	7000	13	360	4.8	1.2	1488	555	565	484	1240	-	-	-	135	φ16	φ22	1"	
DD9/402A	9	9.5	7000	13	360	6	1.2	1488	555	665	484	1240	-	-	-	135	φ16	φ28	1"	
DD11/402A	11	11.6	7000	13	360	7.2	1.2	1488	555	565	484	1240	-	-	-	135	φ16	φ28	1"	
DD15.5/502A	15.5	16.3	12000	17	900	7.5	3	1758	555	665	484	1480	-	-	-	135	φ22	φ35	1"	
DD19/453A	19	20	13500	17	750	8	4	2121	595	665	502	1801	627	587	-	160	φ22	φ35	1"	
DD24/503A	24	25.2	18000	19	1350	10	4	2400	595	665	502	2080	720	680	-	160	φ22	φ42	1"	
DD29/503A	29	30.5	18000	19	1350	12	4	2704	595	665	502	2374	818	778	-	160	φ22	φ42	1"	
DD32/503A	32	33.6	18000	19	1350	14	4	2704	595	665	502	2374	818	778	-	160	φ22	φ54	1"	
DD38/504A	38	39.9	24000	19	1800	14	5.2	3938	785	675	682	3600	930	885	895	170	φ22	φ54	1"	
DD47/554A	47	49.4	30000	25	2400	15.6	5.2	3938	785	775	682	3600	930	885	895	170	φ22	φ54	1"	
DD58/554A	58	60.9	30000	25	2400	20.8	5.2	3978	785	975	682	3600	930	885	895	170	φ28	φ54	1"	
DD72/604A	72	75.6	42000	25	3120	26	5.2	3978	785	1175	682	3600	930	885	895	170	φ28	φ60	1"	
DD79/634A	79	83	46000	25	3200	28.6	5.2	3988	785	1275	682	3620	950	890	890	170	φ35	φ60	1"	
DD88/634A	8	92.4	46000	28	3200	33.8	5.2	3988	785	1375	682	3620	950	890	890	170	φ35	φ60	1"	

### 3、DJ Models ( Fin Spcce 9.0mm)

型号 Model	Capacity kw DT=7K t0=-7℃		Air flow m³/h	Air throw m	Fcn input W	Defrosting(KW)		Overall size(mm)										Pipe dia. mm		Drainage
	R22	R404A				Coil	Water Receiver	A	B	C	D	E	E1	E2	E3	F	Liquid	Gcs		
DJ1.7/311A	1.7	1.8	1500	9	90	1.5	0.5	642	445	465	364	440	-	-	-	105	φ12.7	φ19	1"	
DJ2.2/312A	2.2	2.3	3000	9	180	1.8	0.9	1092	445	465	364	860	-	-	-	120	φ12.7	φ22	1"	
DJ2.7/312A	2.7	2.8	3000	9	180	2.7	0.9	1108	455	465	384	860	-	-	-	120	φ12.7	φ22	1"	
DJ4.2/352A	4.2	4.4	4500	10	280	2.7	0.9	1408	455	465	384	1160	-	-	-	135	φ16	φ22	1"	
DJ5.6/402A	5.6	5.9	7000	13	360	4.8	1.2	1488	555	565	484	1240	-	-	-	135	φ16	φ22	1"	
DJ6.8/402A	6.8	7.1	7000	13	360	6	1.2	1488	555	665	484	1240	-	-	-	135	φ16	φ28	1"	
DJ7.8/402A	7.8	8.2	7000	13	360	7.2	1.2	1488	555	565	484	1240	-	-	-	135	φ16	φ28	1"	
DJ11.5/502A	11.5	12.1	12000	17	900	7.5	3	1758	555	665	484	1480	-	-	-	135	φ22	φ35	1"	
DJ14/453A	14	14.7	13500	17	750	8	4	2121	595	665	502	1801	627	587	-	160	φ22	φ35	1"	
DJ17/503A	17	17.9	18000	19	1350	10	4	2400	595	665	502	2080	720	680	-	160	φ22	φ42	1"	
DJ20/503A	20	21	18000	19	1350	12	4	2704	595	665	502	2374	818	778	-	160	φ22	φ42	1"	
DJ23/503A	23	24.2	18000	19	1350	14	4	2704	595	665	502	2374	818	778	-	160	φ22	φ54	1"	
DJ26/504A	26	27.3	24000	19	1800	14	5.2	3938	785	675	682	3600	930	885	895	170	φ22	φ54	1"	
DJ31/554A	31	32.6	30000	25	2400	15.6	5.2	3938	785	775	682	3600	930	885	895	170	φ22	φ54	1"	
DJ40/554A	40	42	30000	25	2400	20.8	5.2	3978	785	975	682	3600	930	885	895	170	φ28	φ54	1"	
DJ49/604A	49	51.5	42000	25	3120	26	5.2	3978	785	1175	682	3600	930	885	895	170	φ28	φ60	1"	
DJ53.6/634A	53.6	56	46000	25	3200	28.6	5.2	3988	785	1275	682	3620	950	890	890	170	φ35	φ60	1"	
DJ58/634A	58	61	46000	28	3200	33.8	5.2	3988	785	1375	682	3620	950	890	890	170	φ35	φ60	1"	