

RoHS

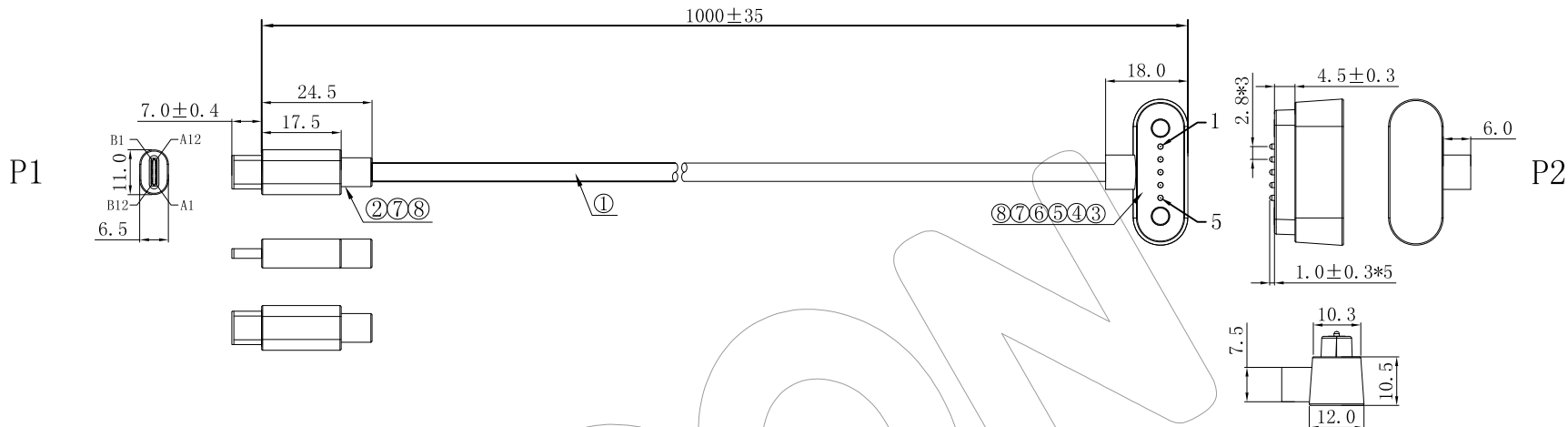

WIRE DIAGRAM

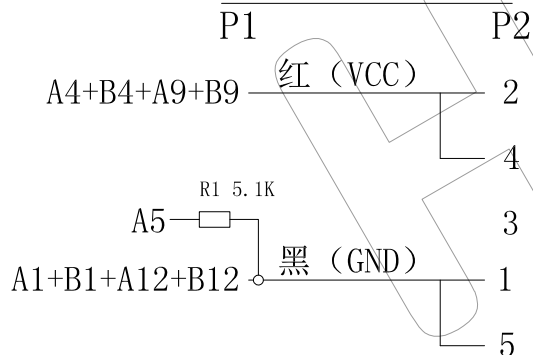

PACKAGE

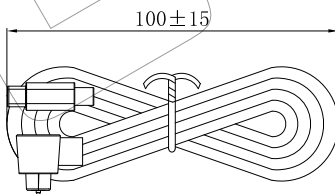

ELECTRONIC TEST:

1. 100% OPEN & SHORT TEST.
2. CONNECTION RESISTANCE: 2.00hm (MAX)
3. INSULATION RESISTANCE: 10M Ohm/DC300V/0.01S

8	PVC	45P-黑色PVC插头料	-	g
7	PE	PE透明内膜料	-	g
6	PCB	5Pin PCB	1	PCS
5	ABS	黑色ABS胶料	-	g
4	磁铁	N52 磁铁 (S)	2	PCS
3	POGO	POGO Pin 探针	5	PCS
2	插头	TYPE-C公头 针镀金G/F 黑胶 镀镍	1	PCS
1	线材	24AWG 2C (红, 黑) OD:4.0 黑色 PVC	-	MM
NO. PART NO.			DESCRIPTION	Q' TY UNIT

OPERATION

X.X	±0.30
X.XX	±0.20
X.XXX	±0.10
Angle	±3°
DIM	TOL

DRAW
CHECK
APPROVE

Lu jin ying

SCALE
FIT
UNIT
mm
SIZE
A4
SHEET
1/1
PROJ.

HECON 东莞市禾康电子有限公司
DONGGUAN HECON ELECTRONICS CO.,LTD

PART NO. HC-PCG-C-05P-1000-02
TITLE: Type-c公头 TO 5PIN POGO PIN磁吸公头

A

REV	DATE	MODIFICATION DESCRIPTION	CHANGE
A0	2022.10.11	NEW DRAWING	