

# X1 robot

Smart Robot Vacuum Cleaner

## Product Specification



CREATULIZE

# Product Diagram

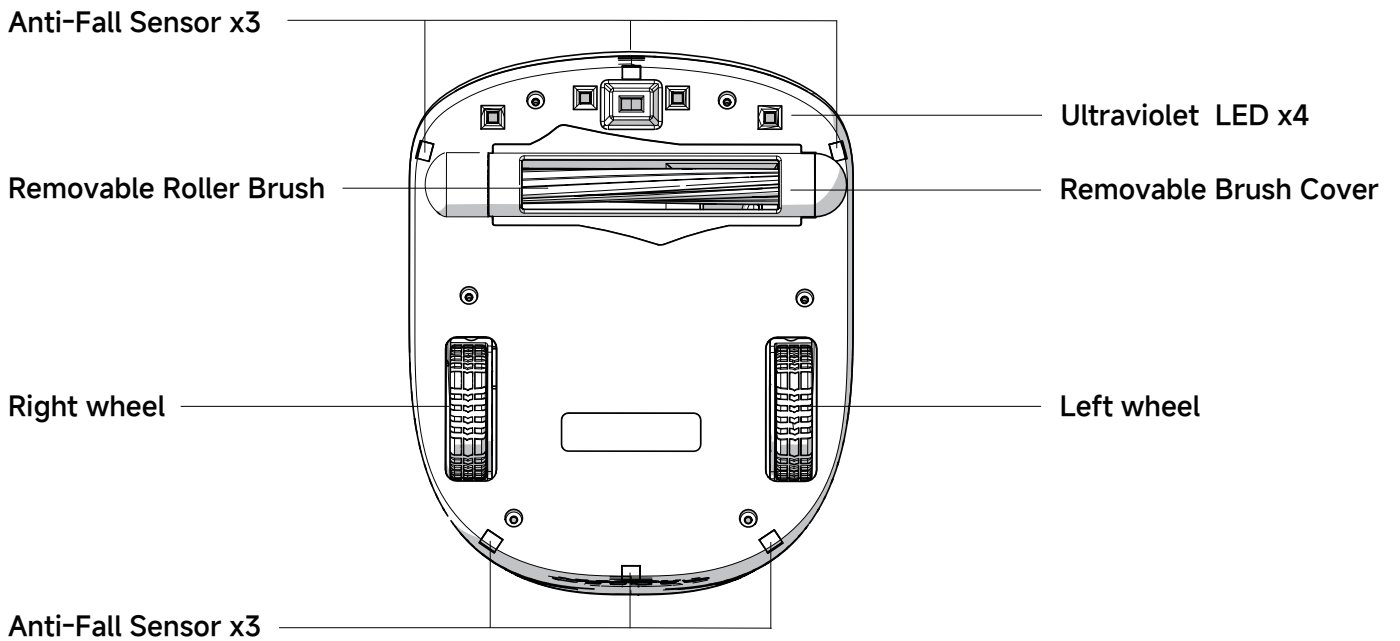
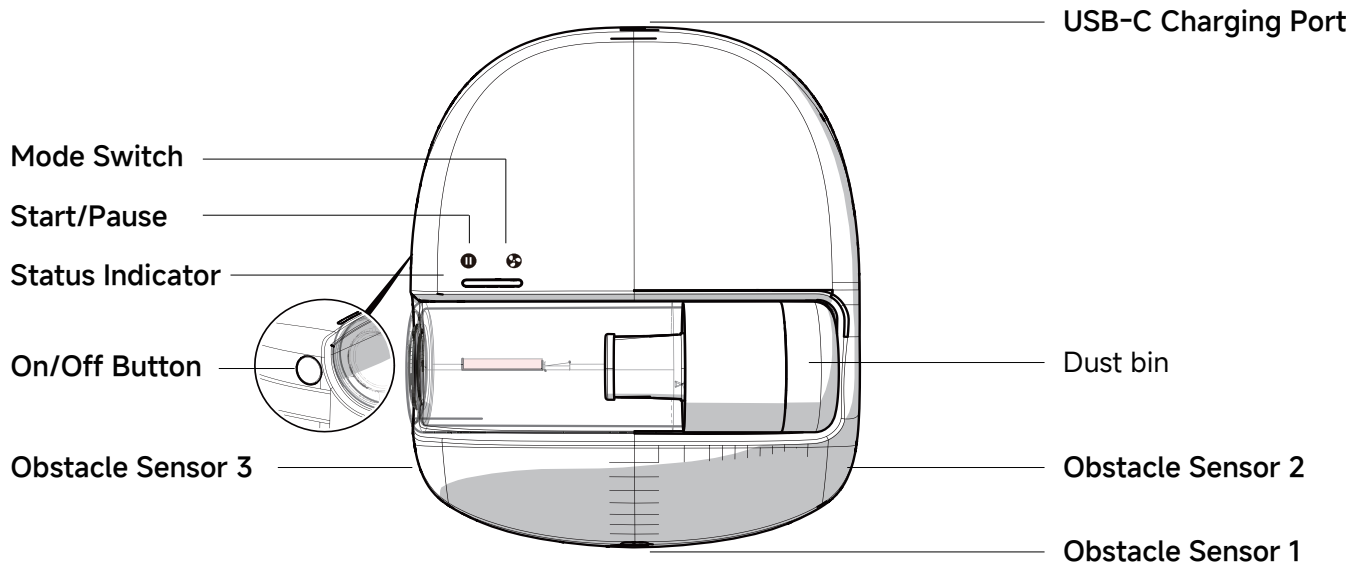

# Technical Specifications

---

## 1. Dimensions and Weight

Volume: 240mm x 196mm x 92mm

Weight: 1.1kg

---

## 2. Battery and Power Supply

Battery Type: Lithium-ion

Battery Voltage: 11.1V

Capacity: 11.1V 2.6Ah

Operating Time: 1 hour (maximum runtime on full charge)

Charging Time: 3 - 3.5 hours

Power Adapter Specifications: 5V/3A, 9V/2A

---

## 3. Sensors and Navigation

Sensor Types: 9 infrared proximity sensors, 6+1 axis IMU

Navigation Technology: S-shaped path planning, real-time mapping, etc.

---

## 4. Cleaning Performance

Suction Power: 14AW

Vacuum Fan Power: 30W

Vacuum Fan Speed: 17,200 RPM

Brush Roll Speed: 5,000 RPM

Brush Roll Motor: Hall-effect sensor-equipped brushless motor

Beating Frequency: 15,000 CPM

---

## 5. Drive Motor Module

Control System: Hall-sensor-based servo system

Motor: Hall-effect sensor-equipped brushless motor

Rotational Speed: 3000 RPM MAX

Gearbox Type: Hub-integrated reduction gear

Suspension System: 18mm effective travel

## 6. Ultraviolet Sterilisation UV Lamp

LED Type: 270nm+400nm UVA+C LED

Beam Angle: 130°

Light Power: 6mW+50mW

Leakage Protection:

- Automatic Mode: Immediately shuts off when absolute angle exceeds 10° or device moves 5cm from surface
- Manual Mode: Immediately shuts off when device moves 5cm from surface

---

## 7. Cleaning Modes

Auto: Powerful Mode, Gentle Mode, Precision Mode

Manual: Manual Mode

---

## 8. Roller Brush Bar Type

Aluminium alloy roller brush shaft + Silicone roller brush bar

---

## 9. Dust Bin Capacity: 260 (ml)

---

## 10. Filtration System

Cyclonic separation, HEPA filtration

---

## 11. Dust Cup Fixing Method

Magnetic attachment with removal detection

---

## 12. Alert Methods

Voice prompts

Light indicators

---

## 13. Environmental Requirements

Operating temperature range: 5°C to 40°C

Relative humidity range: 0% to 80%

